

**BALDOR® • RELIANCE** 

**Product Information Packet**

**VFDL3501M**

**.33HP, 1725RPM, 1PH, 60HZ, 56C, 3414L, TEFC, F1**

Part Detail							
Revision:	F	Status:	PRD/A	Change #:		Proprietary:	No
Type:	AC	Elec. Spec:	34WGW721	CD Diagram:	CD0008	Mfg Plant:	
Mech. Spec:	34M372	Layout:	34LYM372	Poles:	04	Created Date:	11-26-2013
Base:	N	Eff. Date:	07-20-2018	Leads:	7#18		

Specs			
Catalog Number:	VF3DL3501M	Inverter Code:	Not Inverter
Enclosure:	TEFC	KVA Code:	L
Frame:	56C	Lifting Lugs:	No Lifting Lugs
Frame Material:	Steel	Locked Bearing Indicator:	Locked Bearing
Output @ Frequency:	.330 HP @ 60 HZ	Motor Lead Quantity/Wire Size:	7 @ 18 AWG
Synchronous Speed @ Frequency:	1800 RPM @ 60 HZ	Motor Lead Exit:	Ko Box
Voltage @ Frequency:	115.0 V @ 60 HZ	Motor Lead Termination:	Flying Leads
	230.0 V @ 60 HZ	Motor Type:	3414L
XP Class and Group:	None	Mounting Arrangement:	F1
XP Division:	Not Applicable	Power Factor:	60
Agency Approvals:	UR	Product Family:	General Purpose
	CSA	Product Type:	FARM DUTY
Auxillary Box:	No Auxillary Box	Pulley End Bearing Type:	Sealed Bearing
Auxillary Box Lead Termination:	None	Pulley Face Code:	C-Face
Base Indicator:	No Mounting	Pulley Shaft Indicator:	Standard
Bearing Grease Type:	Polyrex EM (-20F +300F)	Rodent Screen:	None
Blower:	None	RoHS Status:	ROHS COMPLIANT
Current @ Voltage:	3.000 A @ 230.0 V	Shaft Extension Location:	Pulley End

	3.600 A @ 208.0 V	<b>Shaft Ground Indicator:</b>	No Shaft Grounding
	6.000 A @ 115.0 V	<b>Shaft Rotation:</b>	Reversible
<b>Design Code:</b>	N	<b>Shaft Slinger Indicator:</b>	Shaft Slinger
<b>Drip Cover:</b>	No Drip Cover	<b>Speed Code:</b>	Single Speed
<b>Duty Rating:</b>	CONT	<b>Motor Standards:</b>	NEMA
<b>Electrically Isolated Bearing:</b>	Not Electrically Isolated	<b>Starting Method:</b>	Direct on line
<b>Feedback Device:</b>	NO FEEDBACK	<b>Thermal Device - Bearing:</b>	None
<b>Front Face Code:</b>	Standard	<b>Thermal Device - Winding:</b>	None
<b>Front Shaft Indicator:</b>	None	<b>Vibration Sensor Indicator:</b>	No Vibration Sensor
<b>Heater Indicator:</b>	No Heater	<b>Winding Thermal 1:</b>	Manual Thermal Overload
<b>Insulation Class:</b>	B	<b>Winding Thermal 1 Location:</b>	KO
		<b>Winding Thermal 2:</b>	None

Nameplate NP1280L									
CAT.NO.	VF DL3501M								
SPEC.	34M372W721G1								
HP	.33								
VOLTS	115/230								
AMP	6/3								
RPM	1725								
FRAME	56C								
				HZ	60			PH	1
SER.F.	1.35			CODE	L		DES	N	CL
									B
NEMA-NOM-EFF	60			PF	60				
RATING	40C AMB-CONT								
CC							USABLE AT 208V	3.6	
DE	6203			ODE	6203				
ENCL	TEFC			SN					
	SFA 6.8/3.4								

Parts List		
Part Number	Description	Quantity
SA273097	SA 34M372W721G1	1.000 EA
RA259701	RA 34M372W721G1	1.000 EA
TPMRD4746SP	THERMAL 1PH 0.75 MAN SPL LOW TEMP	1.000 EA
EC1189A02SP	61B2D120189NNBA ELEC CAP, 189-227MFD, 12	1.000 EA
NS2512A01	INSULATOR, CONDUIT BOX X	1.000 EA
34CB3001A39P	CONDUIT BOX, PRIMER ONLY	1.000 EA
34GS1013SP	GASKET, CONDUIT BOX LEXIDE	1.000 EA
51XB1016A07	10-16 X 7/16 HXWSSLD SERTYB	2.000 EA
11XW1032G06	10-32 X .38, TAPTITE II, HEX WSHR SLTD U	1.000 EA
RM1014A01SP	BUTYL RUB. THRM COV. (MENA)	1.000 EA
HA6001A01	THERMAL RETAINER (PLATED)	1.000 EA
NS2500A02	INSULATOR, MAN THER PROT	1.000 EA
51XB1214A10	12-14 X 5/8HX WS SL SR TYBX	2.000 EA
34EP3102A01SP	FR ENDPLATE, MACH	1.000 EA
HA1005A05SP	SLINGER, OD 1.50, ID .659, 203 BRG	1.000 EA
51XW0832A07	8-32 X .44, TAPTITE II, HEX WSHR SLTD SE	2.000 EA
NS2500A01	INSULATOR, AUTO THER PROT	1.000 EA
34CB4800SP	CAPACITOR COVER, STAMPED PRIMED	1.000 EA
34GS3000SP	GASKET, CAPACITOR BOX	1.000 EA
51XB1016A05	10-16X5/16HX WA SL SR TYB (F/S)	2.000 EA
HW5100A03	WAVY WASHER (W1543-017)	1.000 EA
34EP3300A55	PU ENDPLATE, MACH W/SEAL	1.000 EA
HW4600A54	SEAL 0.668 X 1.064 X 0.250 DOUBLE SHIELD	1.000 EA
HW4600B39SP	V-RING SLINGER 0.550 X 0.790 X .18 VITON	1.000 EA

Parts List (continued)		
Part Number	Description	Quantity
51XN1032A20	10-32 X 1 1/4 HX WS SL SR	2.000 EA
34FN3002A01SP	EXTERNAL FAN, PLASTIC, .637/.639 HUB W/	1.000 EA
34FH4002A01SP	IEC FH NO GREASER PRIMED	1.000 EA
51XW1032A06	10-32 X .38, TAPTITE II, HEX WSHR SLTD S	3.000 EA
36CB4516	36 LIPPED CB LID - GALVANNEAL	1.000 EA
37GS1001SP	GASKET, CONDUIT BOX LID, .06 THICK LEXID	1.000 EA
51XW0832A07	8-32 X .44, TAPTITE II, HEX WSHR SLTD SE	4.000 EA
MJ5001A27	32220KN GRAY SEALER *MIN BUY 4 QTS=1GAL	0.001 QT
HW2501D13	KEY, 3/16 SQ X 1.375	1.000 EA
HA7000A04	KEY RETAINER 0.625 DIA SHAFTS	1.000 EA
HW3001B01	BRASS CUP WASHER, FOR #10 SCREW	1.000 EA
MG1025C02	WILKOFASST SG, 787.105, TAN	0.014 GA
85XU0407S04	4X1/4 U DRIVE PIN STAINLESS	2.000 EA
SP5051B16	MDL 34 TORQ STAT SW,TYPE L , STD F1 & F2	1.000 EA
HA3100A12	THRUBOLT 10-32 X 7.375	4.000 EA
LB1087	LABEL,MANUAL RESET (ROLL LABEL)	1.000 EA
LB1119N	WARNING LABEL	1.000 EA
LC0008	CONNECTION LABEL	1.000 EA
NP1280L	ALUM FARM DUTY UL CSA CC THERMAL	1.000 EA
PK3083T	STYROFOAM PACKING CRADLE	1.000 EA
35PA1000	PKG GRP, PRINT PK1008A06	1.000 EA
PK3088	MICROFOAM, 8"X"8 PERF. SHEETS 5,400/RL	1.000 EA

**AC Induction Motor Performance Data**  
Record # 7081 - Typical performance - not guaranteed values

<b>Winding:</b> 34WGW721-R001	<b>Type:</b> 3414L	<b>Enclosure:</b> TEFC
-------------------------------	--------------------	------------------------

Nameplate Data				230 V, 60 Hz: High Voltage Connection	
Rated Output (HP)	.33			Full Load Torque	1 LB-FT
Volts	115/230			Start Configuration	direct on line
Full Load Amps	6/3			Breakdown Torque	2.95 LB-FT
R.P.M.	1725			Pull-up Torque	2.55 LB-FT
Hz	60	Phase	1	Locked-rotor Torque	3.6 LB-FT
NEMA Design Code	N	KVA Code	L	Starting Current	13 A
Service Factor (S.F.)	1.35			No-load Current	2.6 A
NEMA Nom. Eff.	60	Power Factor	60	Line-line Res. @ 25°C	6.32 Ω A Ph 4.93 Ω B Ph
Rating - Duty	40C AMB-CONT			Temp. Rise @ Rated Load	59°C
S.F. Amps	6.8/3.4			Temp. Rise @ S.F. Load	73°C

Load Characteristics 230 V, 60 Hz, 0.33 HP

% of Rated Load	25	50	75	100	125	150	S.F.
Power Factor	31	41	52	60	67	73	0
Efficiency	33	41	52	60	61.5	61.5	0
Speed	1780	1760	1745	1725	1705	1680	0
Line amperes	2.6	2.7	2.8	3	3.3	3.7	3.4

Performance Graph at 230V, 60Hz, 0.33HP Typical performance - Not guaranteed values

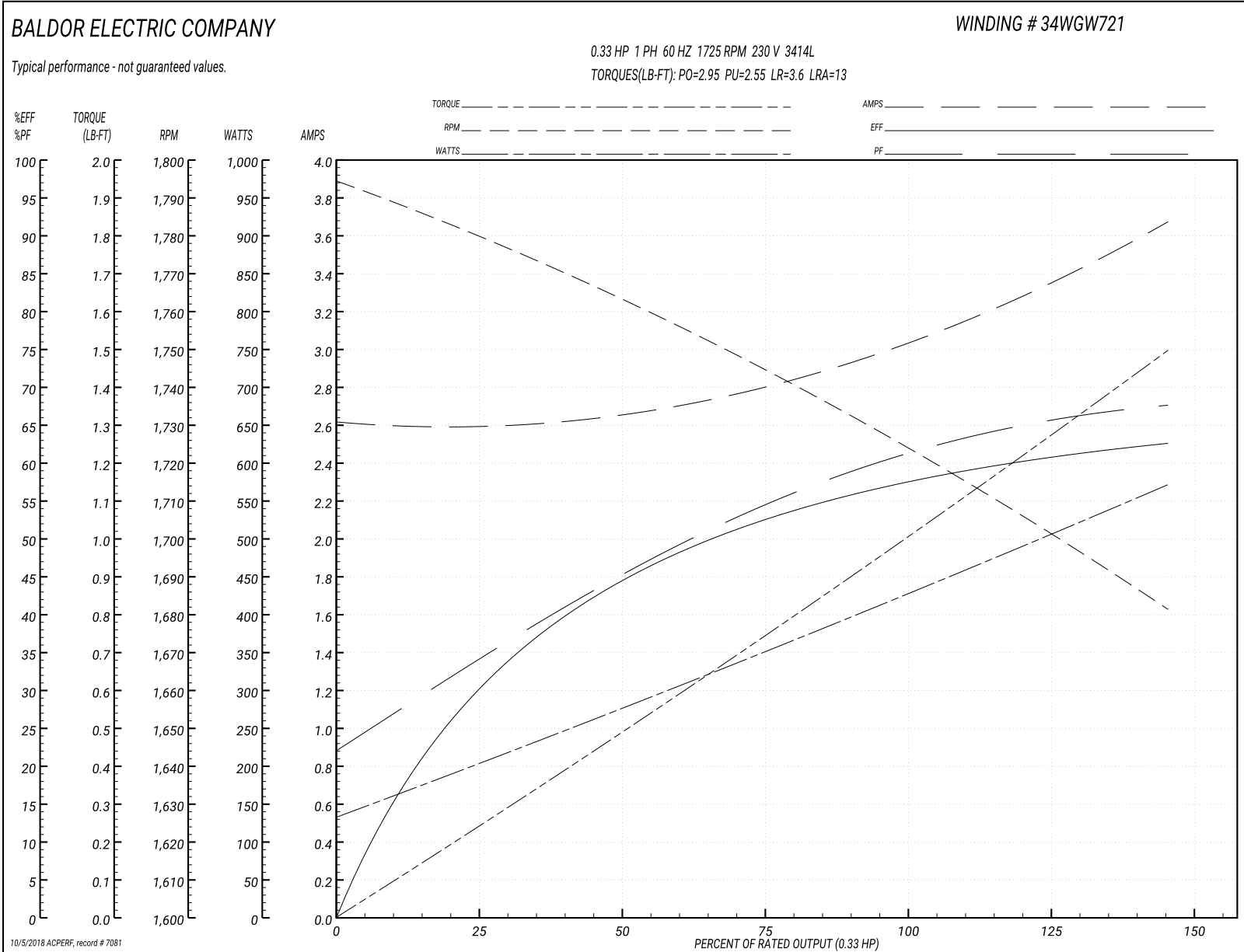



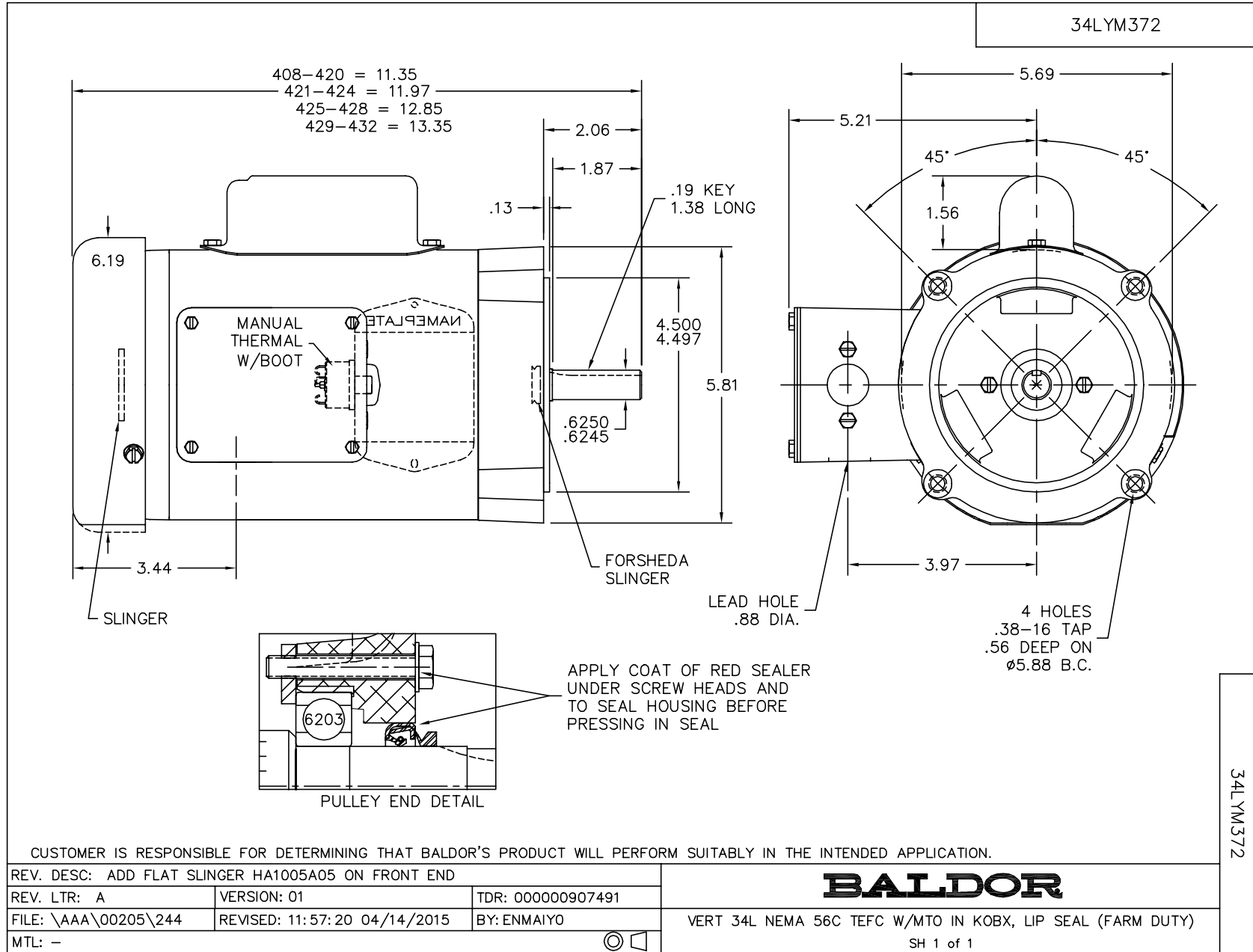

CD0008

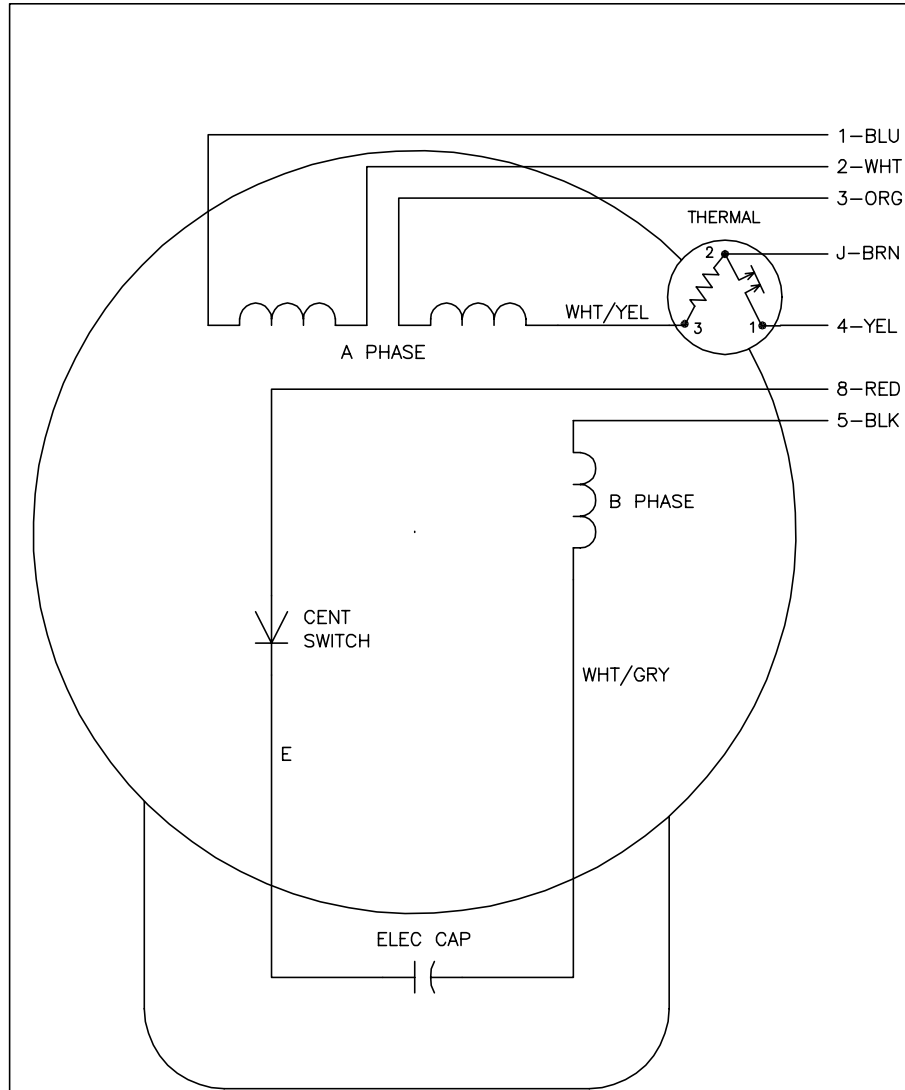

	LINE A	LINE B	JOIN	JOIN
HIGH STD	1	4	2,3,8	J,5
HIGH OPP	1	4	2,3,5	J,8
LOW STD	1,3,8	4	-	2,J,5
LOW OPP	1,3,5	4	-	2,J,8

NOTES:

1. STANDARD ROTATION IS CCW FACING END OPPOSITE SHAFT EXTENSION.
2. MULTIPLE CAPACITORS ARE CONNECTED IN PARALLEL UNLESS OTHERWISE SPECIFIED.
3. LEAD COLORS ARE OPTIONAL. LEADS MUST ALWAYS BE NUMBERED AS SHOWN.

REV. DESC: REMOVE 2-TERMINAL THERMAL DETAIL, SEE CD0008A02		
REV. LTR: F	VERSION: 01	TDR: 000000360649
80000	FILE: \AAA\00007\408	REVISED: 10:56:54 04/18/2005
	MTL: -	BY: ENJOEPO

**BALDOR ELECTRIC Co.**

TYPE L, DV, REV, THERMAL, 7 LEADS

CD0008