

BALDOR® • RELIANCE 

Product Information Packet

CEWDM3709T

7.5HP,3520RPM,3PH,60HZ,213TC,3728M,TEFC

Part Detail							
Revision:	T	Status:	PRD/A	Change #:		Proprietary:	No
Type:	AC	Elec. Spec:	37WGR224	CD Diagram:	CD0005	Mfg Plant:	
Mech. Spec:	37H887	Layout:	37LYH887	Poles:	02	Created Date:	05-10-2012
Base:	RG	Eff. Date:	10-04-2017	Leads:	9#14		

Specs			
Catalog Number:	CEWDM3709T	Heater Indicator:	No Heater
Enclosure:	TEFC	Insulation Class:	F
Frame:	213TC	Inverter Code:	Inverter Ready
Frame Material:	Steel	KVA Code:	J
Output @ Frequency:	7.500 HP @ 60 HZ	Lifting Lugs:	Standard Lifting Lugs
Synchronous Speed @ Frequency:	3600 RPM @ 60 HZ	Locked Bearing Indicator:	Locked Bearing
Voltage @ Frequency:	460.0 V @ 60 HZ	Motor Lead Quantity/Wire Size:	9 @ 14 AWG
	230.0 V @ 60 HZ	Motor Lead Exit:	Ko Box
XP Class and Group:	None	Motor Lead Termination:	Flying Leads
XP Division:	Not Applicable	Motor Type:	3728M
Agency Approvals:	UR	Mounting Arrangement:	F1
	CSA EEV	Power Factor:	84
	CSA	Product Family:	Wash Down
Auxillary Box:	No Auxillary Box	Pulley End Bearing Type:	Sealed Bearing
Auxillary Box Lead Termination:	None	Pulley Face Code:	C-Face
Base Indicator:	Rigid	Pulley Shaft Indicator:	Standard
Bearing Grease Type:	Polyrex EM (-20F +300F)	Rodent Screen:	None
Blower:	None	Shaft Extension Location:	Pulley End

Current @ Voltage:	18.000 A @ 230.0 V	Shaft Ground Indicator:	No Shaft Grounding
	19.400 A @ 208.0 V	Shaft Rotation:	Reversible
	9.000 A @ 460.0 V	Shaft Slinger Indicator:	Shaft Slinger
Design Code:	A	Speed Code:	Single Speed
Drip Cover:	No Drip Cover	Motor Standards:	NEMA
Duty Rating:	CONT	Starting Method:	Direct on line
Electrically Isolated Bearing:	Not Electrically Isolated	Thermal Device - Bearing:	None
Feedback Device:	NO FEEDBACK	Thermal Device - Winding:	None
Front Face Code:	Standard	Vibration Sensor Indicator:	No Vibration Sensor
Front Shaft Indicator:	None	Winding Thermal 1:	None
		Winding Thermal 2:	None

Nameplate NP1669L										
CAT.NO.	CEWDM3709T									
SPEC.	37H887R224G1									
HP	7.5									
VOLTS	230/460									
AMP	18/9									
RPM	3520									
FRAME	213TC				HZ	60			PH	3
SER.F.	1.15		CODE	J	DES	A		CLASS	F	
NEMA-NOM-EFF	89.5		PF	84						
RATING	40C AMB-CONT									
CC	010A				USABLE AT 208V			19.4		
DE	6307				ODE	6206				
ENCL	TEFC		SN							
BLANK										

Parts List		
Part Number	Description	Quantity
SA244917	SA 37H887R224G1	1.000 EA
RA231804	RA 37H887R224G1	1.000 EA
36FN3000B02	EXFN, PLASTIC, 6.00 OD, 1.175 ID	1.000 EA
HW3200A01	3/8-16X3/4 I-BLT WELDED F/S	1.000 EA
37CB3005A04W	CASTING W/.75 NPT@6(MACH WHITE)	1.000 EA
37GS1025	37 MOLDED GASKET W/LIP, LEAD SEAL	1.000 EA
51XW2520A12	.25-20 X .75, TAPTITE II, HEX WSHR SLTD	2.000 EA
HA5027A01	HA4066A01 T-DRAIN X2 BAGGED	1.000 EA
11XW1032G06	10-32 X .38, TAPTITE II, HEX WSHR SLTD U	1.000 EA
37EP3101A94MW	FRONT TEFC L&M 206 BRG W/O GR SR (WHITE)	1.000 EA
HW4032A01	BLACK DRAIN PLUG FOR WASH DOWN MOTORS	3.000 EA
HW5100A06	W2420-025 WVY WSHR (WB)	1.000 EA
37EP3300A23MW	WHITE EPOXY EP MACH COMPL	1.000 EA
HW4032A01	BLACK DRAIN PLUG FOR WASH DOWN MOTORS	3.000 EA
HW4600B51	SEAL 1.375 X 2.125 X 0.313 SINGLE LIP DB	1.000 EA
10XN2520S30	1/4-20 X 1 7/8 HEX HEAD SS	4.000 EA
XY3118S12	5/16-18 HEX NUT, STAINLESS STEEL	4.000 EA
07FH4011	WASHDOWN IEC FH W/PRIMED	1.000 EA
11XW1032S06	10-32 X .38, TAPTITE II, HEX WSHR SLTD U	3.000 EA
HW4600B74	V-RING SLINGER 1.125 X 1.445 X .24 VITON	1.000 EA
HW4600B31SP	V-RING SLINGER 1.438 X 1.758 X .24 VITON	1.000 EA
37CB4512	CONDUIT BOX LID FOR WASHDOWN 37 FRAME	1.000 EA
37GS1008A02	37 GS FOR CB LID - WHITE NEOPRENE	1.000 EA
59XW0832S07	TAPTITE II,HEX WSHR UNSLTD SER,410 S.S.,	4.000 EA

Parts List (continued)		
Part Number	Description	Quantity
HW2502F21	#303 SS,SQ KEY 5/16 X 2.375	1.000 EA
HA7000A02	KEY RETAINER RING, 1 1/8 DIA, 1 3/8 DIA	1.000 EA
MJ5001A27	32220KN GRAY SEALER *MIN BUY 4 QTS=1GAL	0.001 QT
MJ5001A02	732 CL SEALANT 3 OZ DIXIE BEARING 289100	0.001 EA
85XU0407S04	4X1/4 U DRIVE PIN STAINLESS	2.000 EA
LB1115N	LABEL,LIFTING DEVICE (ON ROLLS)	1.000 EA
LB1164	LABEL,WARNING AND DRAIN	1.000 EA
MJ1000A02	GREASE, POLYREX EM EXXON (USe 4824-15A)	0.050 LB
MG1025Z02	ACTIVATOR WILKOFAS 060.02HF	0.010 GA
MG1025W01	WILKOFAS 781.01, SIGNAL WHITE #9003	0.028 GA
51XB1214A20	12-14X1.25 HXWSSLD SERTYB	1.000 EA
HA3104S14	300UBOLT 12.125LG SS	4.000 EA
LC0005	CONN.DIA.,TY M,9-LD,DUAL VOLT,REVERSING	1.000 EA
NP1669L	SS WD SUPER-E UL CSA-EEV PREM REV MTG	1.000 EA
G0PA1000	PKG GRP, PRINT PK1026A06	1.000 EA
MN416A01	TAG-INSTAL-MAINT no wire (1200/bx) 5/18	1.000 EA

AC Induction Motor Performance Data

Record # 53378 - Typical performance - not guaranteed values

Winding: 37WGR224-R033	Type: 3728M	Enclosure: TEFC
-------------------------------	--------------------	------------------------

Nameplate Data				460 V, 60 Hz: High Voltage Connection	
Rated Output (HP)	7.5			Full Load Torque	10.9 LB-FT
Volts	230/460			Start Configuration	direct on line
Full Load Amps	18/9			Breakdown Torque	40.4 LB-FT
R.P.M.	3520			Pull-up Torque	20.6 LB-FT
Hz	60	Phase	3	Locked-rotor Torque	21.8 LB-FT
NEMA Design Code	A	KVA Code	J	Starting Current	68.4 A
Service Factor (S.F.)	1.15			No-load Current	3.73 A
NEMA Nom. Eff.	89.5	Power Factor	84	Line-line Res. @ 25°C	1.1531 Ω
Rating - Duty	40C AMB-CONT			Temp. Rise @ Rated Load	45°C
S.F. Amps				Temp. Rise @ S.F. Load	54°C
				Locked-rotor Power Factor	33
				Rotor inertia	0.255 LB-FT ²

Load Characteristics 460 V, 60 Hz, 7.5 HP

% of Rated Load	25	50	75	100	125	150	S.F.
Power Factor	45	69	79	84	87	89	86
Efficiency	81.5	88.8	90.5	90.6	90.1	89.2	90.3
Speed	3580.5	3562.7	3541.6	3520.3	3496.3	3470.9	3506
Line amperes	4.22	5.36	7.03	8.94	11	13.1	10.2

Performance Graph at 460V, 60Hz, 7.5HP Typical performance - Not guaranteed values

BALDOR ELECTRIC COMPANY

WINDING # 37WGR224

Typical performance - not guaranteed values.

7.5 HP 3 PH 60 HZ 3520 RPM 460 V 3728M

TORQUES(LB-FT): PO=40.4 PU=20.6 LR=21.8 LRA=68.4

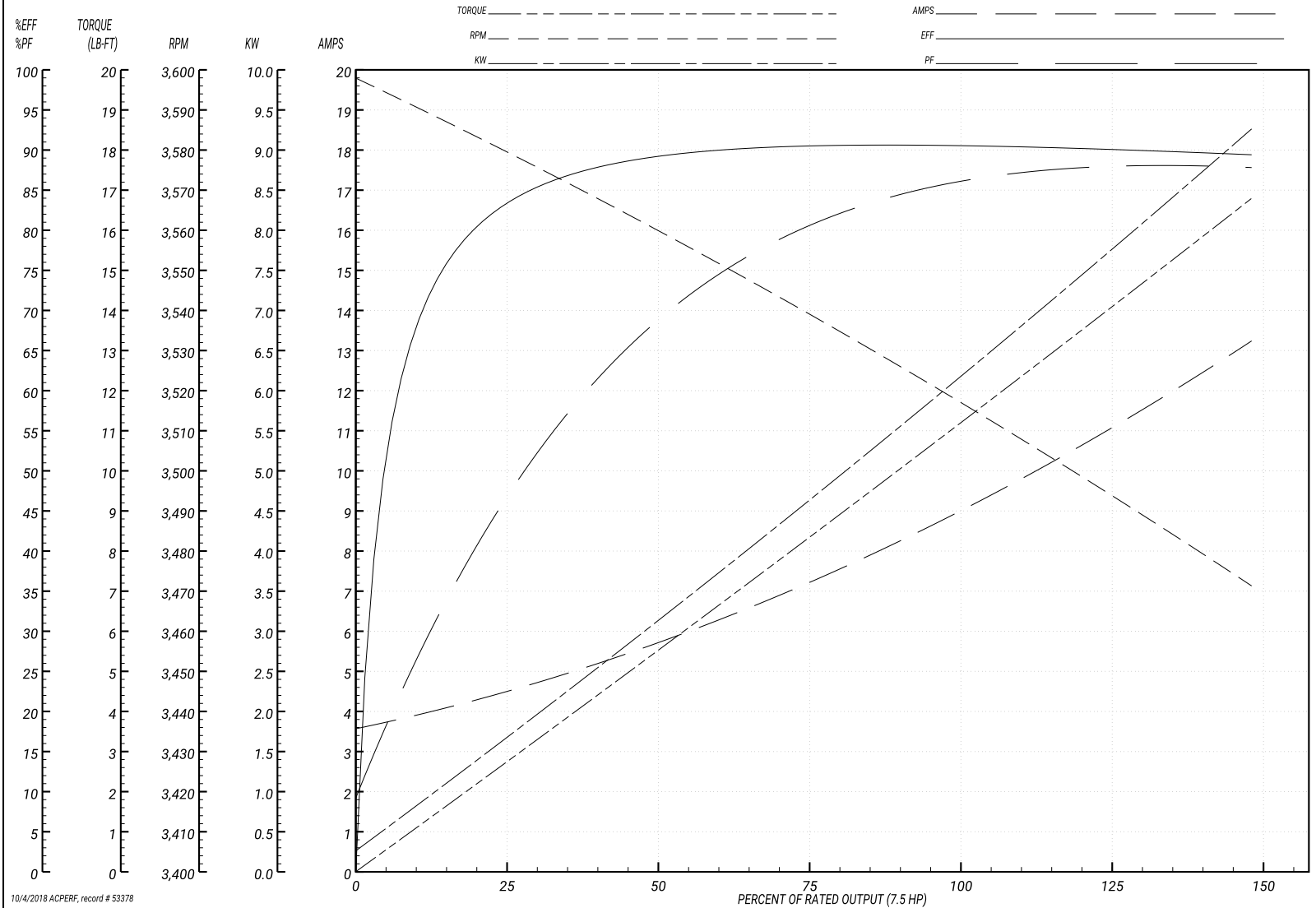

10/4/2018 ACPERF, record # 53378

37LYH887

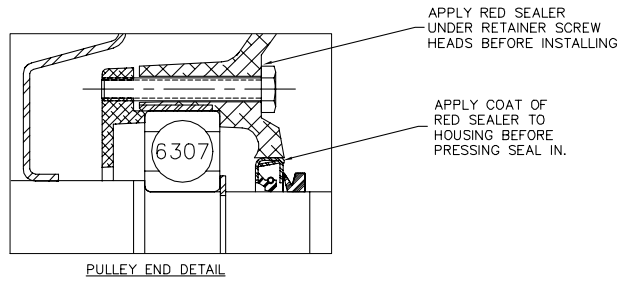
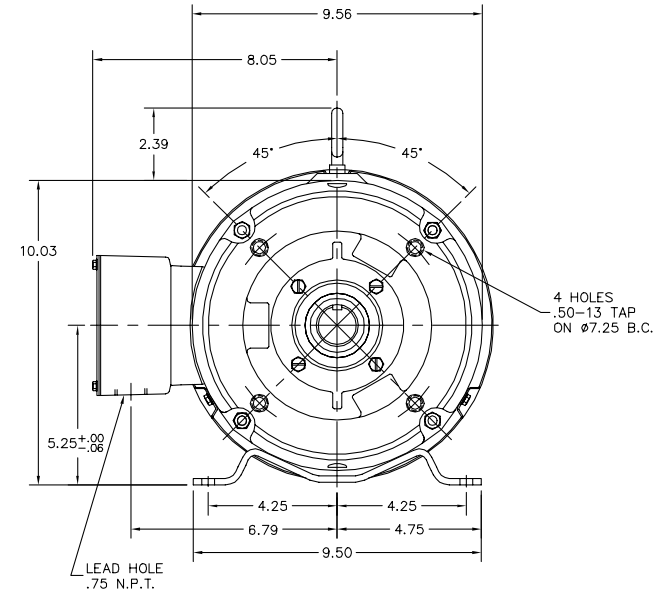
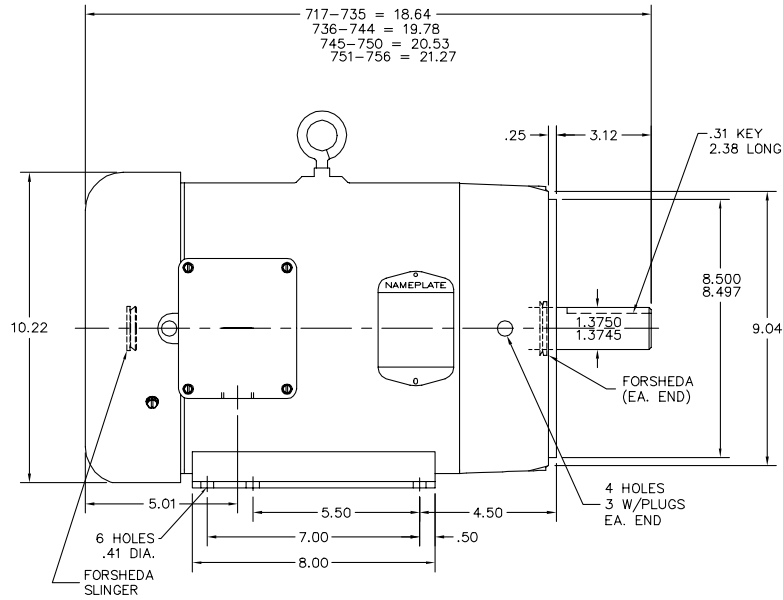

CUSTOMER IS RESPONSIBLE FOR DETERMINING THAT BALDOR'S PRODUCT WILL PERFORM SUITABLY IN THE INTENDED APPLICATION.

REV. DESC: REPLACE HA1005A02 WITH HW4600B74	VERSION: 02	TDR: 000000783785
REV. LTR: B	FILE: \AAA\00093\297	BY: ENCARJ0
MTL: -	REVISED: 03:10:33 05/03/2013	

BALDOR
 STD HORZ 213-5TC TEFC 37M WD
 SH 1 of 1

37LYH887

CD0005



LOW VOLTAGE
(2Y)

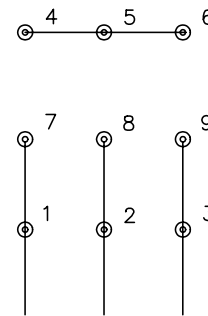

LINE

HIGH VOLTAGE
(1Y)

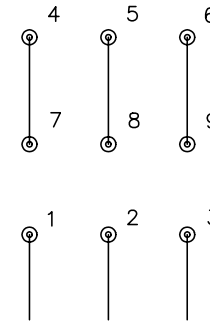

LINE

NOTES:

1. INTERCHANGE ANY TWO LINE LEADS TO REVERSE ROTATION.
2. OPTIONAL THERMOSTATS ARE PROVIDED WHEN SPECIFIED.
3. ACTUAL NUMBER OF INTERNAL PARALLEL CIRCUITS MAY BE A MULTIPLE OF THOSE SHOWN ABOVE.
4. LEAD COLORS ARE OPTIONAL. LEADS MUST ALWAYS BE NUMBERED AS SHOWN.

REV. DESC: REVISE TO SHOW OPTIONAL COLORS			
REV. LTR: E	BY: JLP	REVISED: 01/19/99 10:15	TDR: 0171435
900000		FILE: AAA00005140	MDL: -
		MTL: -	

BALDOR ELECTRIC Co.

3PH, DV, 9 LEADS

CD0005