



# General Information

---

## **1. Deep Groove Ball Bearings**

---

## **2. Angular Contact Ball Bearings**

---

## **3. Self-aligning Ball Bearings**

---

## **4. Cylindrical Roller Bearings**

---

## **5. Tapered Roller Bearings**

---

## **6. Four-row Tapered Roller Bearings**

---

## **7. Spherical Roller Bearings**

---

## **8. Thrust Ball Bearings**

---

## **9. Spherical Roller Thrust Bearings**

---

## **10. Precision Machine Tool Bearings**

---

- High-speed Angular Contact Ball Bearings  
Type BNH000
- Combination Angular Contact Ball Bearings  
Type TAH10, TBH10
- Double direction Thrust Angular Contact Ball Bearings  
Type TAD20
- Flanged-cup Tapered Roller Bearings
- Cross Tapered Roller Bearings
- Ball Screw Support Bearings

## **11. Automotive Bearings**

---

## **12. Bearings for Rolling Stocks**

---

## **13. Sheave Bearings**

---

## **14. Ball Bearing Units**

---

## **15. Plummer Block Housings**

---

# Deep-groove Ball Bearings

---

Because of their versatility, Single-row, Deep-groove Ball Bearings are the most popular of all the ball bearing types. NACHI Deep-groove Ball Bearings are available in a wide range of series defined by the JIS(ISO) standard dimension plan and are also made to meet specialized dimension and configuration requirements. NACHI Deep-groove Ball Bearings are manufactured in both standard precision grade (ISO Grade 0 - ABEC Grade 1) as well as in high-precision grades.

[Table 1](#) shows common, standard configurations of Single-row Deep-groove Ball Bearings.

[Table 2](#) shows a comparison of general characteristics of seal and shield designs for Single-row, Deep-groove Ball bearings.

## Attention

- (1) Deep-groove Ball Bearings can sustain radial, axial or composite loads.  
However when excessive axial load is applied, please consult with NACHI.
- (2) Because sealed or shielded bearings are designed for inner ring rotating applications, the filled grease may leak when they are used with a high speed outer ring rotating condition.  
In such a case, please contact NACHI.
- (3) When bearings with contact rubber seals are used in a severe operating condition such as high speed or high temperature, the filled grease may leak.  
In such a case, a design change or another kind of grease is required.
- (4) When a bearing is mounted on a shaft (into a housing), force should only be applied to the side face of the inner (outer) ring.
- (5) The sealed or shielded bearings should not be washed or heated before mounting.
- (6) It should be noted that mounting errors such as misalignment of the bearing rings cause an appreciable increase in noise level.
- (7) The bearings must always be subjected to a minimum load to prevent sliding movements occurring between the balls and the raceways.

**Table 1. Standard Configuration of Single-row, Deep-groove Ball Bearings**

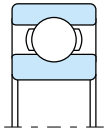
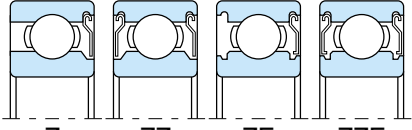
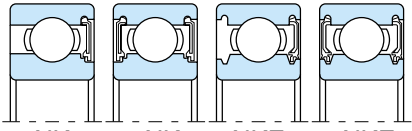
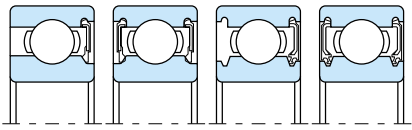
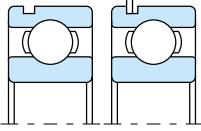
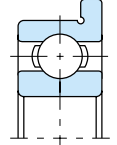
Configuration *		Design	Cross section
Open (no seals, shields)		Consists of inner and outer rings, balls, and cage.	 Open
Sealed or shielded Bearings	Shield	One or two steel shields provide labyrinth clearance	 Z ZZ ZE ZZE
	Non-contact Rubber Seal	One or two non-contact rubber seals provide labyrinth clearance	 NK 2NK NKE 2NKE
	Contact Rubber Seal	One or two contact rubber seals in contact with inner ring	 NSL 2NSL NSE 2NSE
Snap-ring Groove in Outer Ring	N: with snap-ring groove in outer ring. NR: with groove and snap ring in outer ring. (Use of snap ring allows easy mounting and simplified housing design.) Bearings may also be sealed or shielded.		 N NR
Flanged Outer Ring	With flanged outer ring. Applicable to Extra-small and Miniature bearings. Bearings may also be sealed or shielded.		 Flanged Type

Note : One seal or shield type bearings may have a seal groove on the other side.

**Table 2. Comparison of Seal and Shield Characteristics**

Characteristics	Shield (Z, ZE)	Non-contact Rubber Seal (NK, NKE)	Contact Rubber Seal (NSL, NSE)
Friction torque	Low	Low	Higher than NK,NKE, Z and ZE
High speed	Excellent	Excellent	Good (There is some limitation)
Grease sealing	Good	Better than Z,ZE	<ul style="list-style-type: none"> <li>· Excellent at low speed</li> <li>· The grease may leak from the bearing at high speeds and high temperature.</li> <li>· The grease may leak in case of outer ring rotation.</li> </ul>
Dust proofing	Good	Better than Z,ZE	Excellent (Can be used in severe dust environments)
Water proofing	unsuitable	unsuitable	Excellent
Recommended operation temperature range for standard filled grease	-25 ~ 120°C	-25 ~ 120°C	-25 ~ 100°C

# Angular Contact Ball Bearings

---

Angular Contact Ball Bearings can sustain combined loads of simultaneously acting radial and axial loads because they have a contact angle ( $\alpha$ ). The contact angle is defined as the angle between the line joining the points of contact between the ball and the raceways in the radial plane.

## Single - row Angular Contact Ball Bearings

These bearings are designed with three contact angle classifications as shown in [Table 1](#).

Normally, contact angle A design and B design are fitted with a cage as shown in [Table 2](#). High precision (JIS/ISO class 5 or higher) may be fitted with a machined cage of bronze or phenolic resin or a polyamide cage.

Contact angle C design are generally applied high precision, JIS (ISO) class 5 or higher, and are fitted with a machined phenolic resin cage or a polyamide cage.

## Combination Angular Contact Ball Bearings

Single-row Angular Contact Ball Bearings are seldom used as a single unit. Normally they are used as a combination of two and more units.

High precision paired combination Angular Contact Ball Bearings (JIS/ISO class 5 or higher) are used for applications such as machine tool spindles and are usually preloaded.

Three types of combinations are available :

- 1) DB, back - to - back
- 2) DF, face - to - face
- 3) DT, tandem

Because clearance of matched set parts is adjusted before shipment, care should be taken to prevent mixing of parts from other sets. Load-carrying capability of combined Angular Contact Bearings are shown in [Table 3](#).

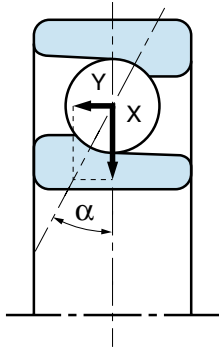

**Table 1. Contact Angle and Characteristics of Single-row Angular Contact Ball Bearings**

Contact Angle Symbol	Contact Angle ( $\alpha$ )	Example Bearing No.	Load capability comparison <sup>(2)</sup>			Cross Section
			Speed	Radial Load Direction (X)	Axial Load Direction (Y)	
A	30°	7205 <sup>(1)</sup>	–	–	–	
B	40°	7205B	Less	Less	Greater	
C	15°	7205C	Greater	Greater	Less	



Note 1) Contact angle symbol "A" is omitted.

2) Axial load can be accommodated in one direction only.

**Table 2. Standard Cage Materials**  
(For JIS/ISO class 0 or 6)

Series	Applicable Bore Diameter Number	
	Pressed Steel	Machined Brass
72, 72B	00 ~ 22	24 ~ 40
73, 73B	00 ~ 19	20 ~ 40

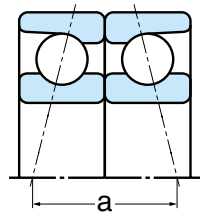
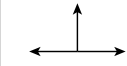
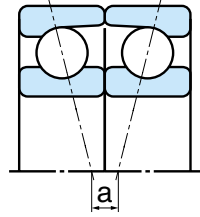
**Table 3. Load-carrying Characteristics of Combination Angular Contact Ball Bearings**

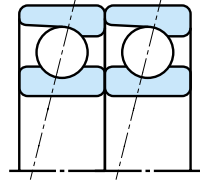
Configuration	Load Center Distance	Load Capability	Moment Load Rigidity	Cross Section
Back - to - Back (DB)	Long		High	
Face - to - Face (DF)	Short		Low	
Tandem (DT)	-		-	



## Flush ground set combinations (Universal matching)

NACHI Angular Contact Ball Bearings with a suffix U are flush ground to permit the use of random combinations where two or more bearings are mounted.

## Speed Limits

With respect to single-row or combination bearings, the dimension tables show limiting speed for bearings made with machined cages or a polyamide cages. For bearings made with pressed-cages, multiply the table limit by 0.8.

For contact angle C design bearings, the table limiting speeds are applied to high precision bearings of class 5 or higher.

These limiting speeds can be applied when a high quality grease or oil is supplied in proper quantity under light load conditions. When Angular Contact Ball Bearings are used in combination of two or more units, or with larger preload to improve rigidity, the limiting speed must be decreased. Please contact NACHI for design assistance.

## Double-row Angular Contact Ball Bearings

This type bearings is made in two contact angle levels as shown in Table 4.

They are selected according to sustained axial and moment load.

Pressed steel cage are used for them.

Some sizes of Double-row Angular Contact Ball Bearing are available with contact seals (2NS) or shields (ZZ).

**Table 4. Double-row Angular Contact Ball Bearing Contact Angles and Symbols**

Contact Angle Symbol	Contact Angle ( $\alpha$ )	Example Bearing No.
None	20°	5205
A	30°	5205A

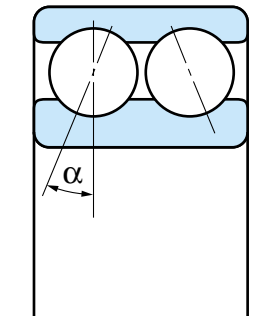





## Attention

- (1) If bearings are operated under severe conditions such as close to limiting speed, high temperature, or vibrating load, please consult NACHI.
- (2) Bearings with polyamide cage should be use at less than 120°C.
- (3) Combination Angular Contact Ball Bearings should not be mixed with those of other bearings.
- (4) When combination bearings with a optional preload is required, please contact NACHI.

# Self-aligning Ball Bearings

## Design

Self-aligning Ball Bearings are particularly suitable for applications where misalignment occurs from errors in mounting or from shaft deflection.

For applications where the bearing load (particularly axial load) carrying capacity is insufficient, spherical roller bearings, which have the same self-aligning property, should be used instead.

## Cage

Bearings are fitted with pressed steel cage or polyamide cage.

The suffix G of bearing number on the packing surface indicate polyamide cage.

## Attention

- (1) Maximum permissible misalignment angle is about  $2.5^\circ$  in the 12 and 22 series, and about  $3^\circ$  in the 13 and 23 series under general service conditions. Care must be taken to provide sufficient clearance between the bearing and surrounding structure when bearing is operating in the full misaligned condition.
- (2) Misaligned bearings will have a tendency to become noisy as speed increases. Due to noise-level constraints, the practical maximum misalignment may be considerably less than the maximum misalignment.
- (3) The dimension tables show the width of the ball assembly as dimension B1 for larger bore sizes of Self-aligning Ball Bearings where width of the ball assembly extends beyond the ring width envelope.
- (4) It is difficult to correctly measure the running clearance of bearings with tapered bore after mounting. Mounting of this type of bearing with tapered bores requires some experience and technique.
- (5) The bearings with polyamide cage should be used at less than  $120^\circ\text{C}$  operating temperature.

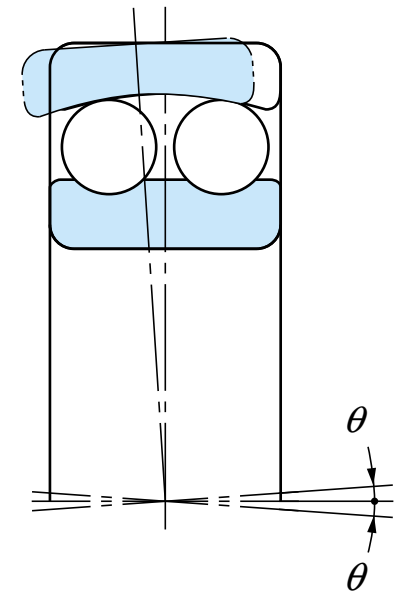

# Cylindrical Roller Bearings

## Designs and Configurations

NACHI Cylindrical Roller Bearings are produced in a wide variety of designs and configurations.

### Conventional Design

Cylindrical Roller Bearings of conventional design are available in 10 configurations as shown in Fig. 1.

Configurations N, NU, NN and NNU will not sustain axial loading. These configurations must be used as the float end bearing.

Configurations NF, NJ, NUH are designed with the capability of sustaining axial loading in one direction.

Configuration NUH is basically an NU bearing with the addition of a guide ring (an "L" ring).

The NUH dimensional data is the same as the NH bearing configuration.

Configuration NF, NJ, and NUH can sustain axial loading in one direction.

Configuration NH, NP, and NUP have bi-directional thrust load-carrying-capability.

The suffix of the bearing number indicates:

E : high capacity

G : polyamide cage

The bearing with polyamide cage should be used at less than 120°C operating temperature.

**Fig 1. Cylindrical Roller Bearing Configurations**

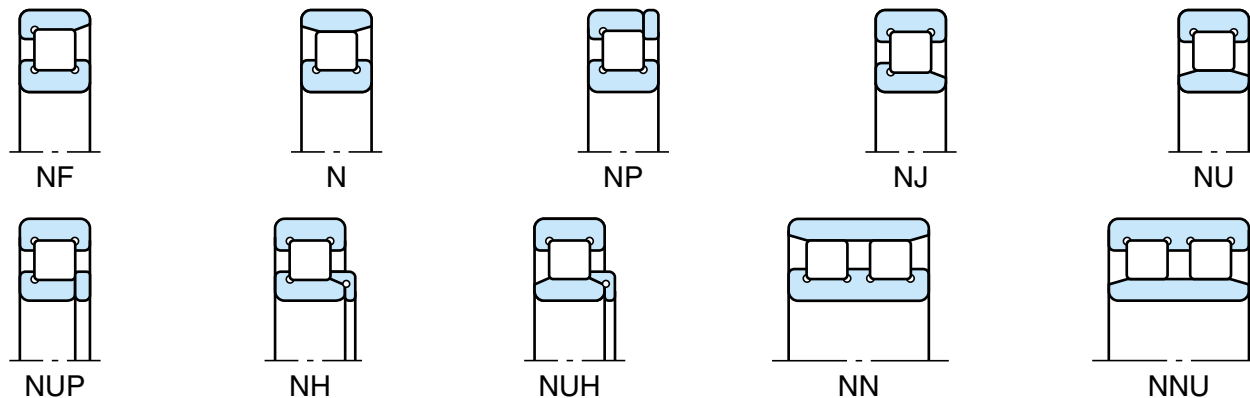
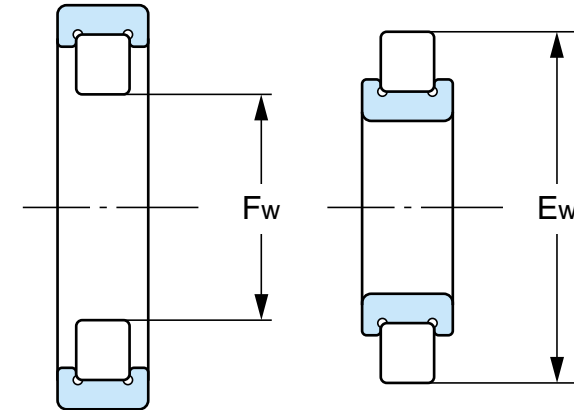

**Table 1. Interchangeable Cylindrical Roller Bearings : Tolerance of Inscribed and Circumscribed Diameters**

**Table 1. Interchangeable Cylindrical Roller Bearings:  
Tolerance of Inscribed and Circumscribed Diameters**

Unit:  $\mu\text{m}$ 

Nominal bore dia. d (mm)		Tolerance of $F_w$ <sup>(1)</sup>		Tolerance of $E_w$ <sup>(2)</sup>	
Over	Incl.	High	Low	High	Low
–	20	+10	0	0	–10
20	50	+15	0	0	–15
50	120	+20	0	0	–20
120	200	+25	0	0	–25
200	250	+30	0	0	–30
250	315	+35	0	0	–35
315	400	+40	0	0	–40
400	500	+45	0	–	–



Notes: (1) Tolerance of inscribed circle diameter  
(2) Tolerance of circumscribed circle diameter

Remarks: Interchangeable cylindrical roller bearing means that a separable ring can be replaced by another ring of the bearing with the same bearing number without impairing the function of the bearing.

# Tapered Roller Bearings

## Interchangeability

Bearings designated as E ..... J (E prefix and J suffix) comply with ISO standards in sub-unit dimensions. The cups and cones of these bearings are internationally interchangeable.

## Inch-dimensioned Series

NACHI manufactures inch-dimensioned series Tapered Roller Bearings to ABMA (ANSI) standards.

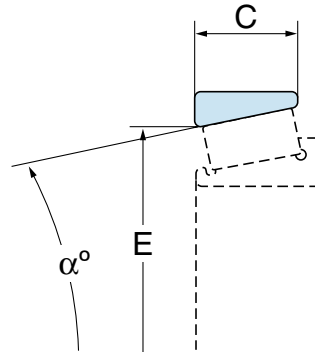

**Fig 1. Sub-unit dimensions**

- $\alpha$  : Contact angle
- C : Cup width
- E : Cup small inside diameter





## Combination and Double-row Tapered Roller Bearings

When radial loads act on a Tapered roller bearing, an axial load is generated from the reaction of the internal contact angle of the bearing. This induced axial load creates a separating force on the cup and cone which is normally offset by mounting Tapered roller bearings in pairs or as multi-row sets.

Table 1 shows combination and double-row mounting of Tapered roller bearings.

**Table 1. Double-row Tapered Roller Bearing Configurations and Features**

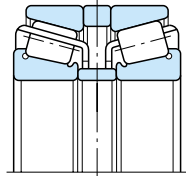
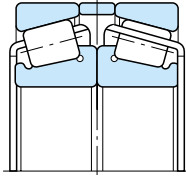
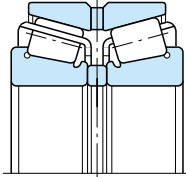
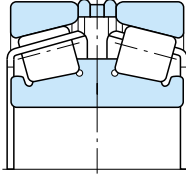
Series or Configuration	Cross section	Example Bearing Number	Adjustment
Back-to-back (DB mounting)		E32208JDB10	Combination of two standard single-row Tapered roller bearings. Two mounting systems are used; one using preset spacers, and the other requiring adjustment using either torque or end-play control.
Face-to-face (DF mounting)		E32208JDF	
KBE KDE		150KBE030	Either double inner or outer ring. Adjustment is normally done using spacers. If spacers are not used, please contact NACHI for end-play specifications.
KBD		150KBD030	

# Four-row Tapered Roller Bearings

---

## Design and Features

Four-row Tapered Roller Bearings are used for the roll necks of rolling mills and are designed to provide the maximum load capacity within a limited envelope size while allowing ease of inspection and maintenance.

Pin-type cages and hollow rollers are used in some of the larger bore sizes to maximize load capacity.

## Recommended Fit (cylindrical bore)

Metric series [Table 1 and 2](#)

Inch series [Table 3 and 4](#)

## Bearing Clearance

Cylindrical-bore, Four-row Tapered Roller Bearings used for rolling mill roll necks have a C2 or smaller clearance. If selection of special radial clearance is required for special service conditions, contact NACHI.

Bearing clearance for Four-row Tapered roller bearings is factory-adjusted as a set and the individual parts of a set must be mounted according to the set marks.

**Table 1. Four-row Bearing Roll Neck Fits  
(Metric Series)**

Unit :  $\mu\text{m}$

Nominal bearing bore diameter d (mm)		Single plane mean bore diameter deviation $\Delta d_{mp}$		Roll neck diameter deviation		Fit clearance		Wear limit of roll neck (Reference)
Over	Incl.	High	Low	High	Low	Min	Max	
80	120	0	-20	-120	-150	100	150	300
120	180	0	-25	-150	-175	125	175	350
180	250	0	-30	-175	-200	145	200	400
250	315	0	-35	-210	-240	175	240	480
315	400	0	-40	-240	-300	200	300	600
400	500	0	-45	-245	-300	200	300	600
500	630	0	-50	-250	-300	200	300	600

**Table 2. Four-row Bearing Chock Fits  
(Metric Series)**

Unit :  $\mu\text{m}$

Nominal bearing outside diameter D (mm)		Single plane mean bore diameter deviation $\Delta D_{mp}$		Chock inside diameter deviation		Fit clearance		Wear limit of chock inside diameter (Reference)
Over	Incl.	High	Low	High	Low	Min	Max	
120	150	0	-20	+60	+25	25	80	160
150	180	0	-25	+125	+50	50	150	300
180	250	0	-30	+120	+50	50	150	300
250	315	0	-35	+115	+50	50	150	300
315	400	0	-40	+110	+50	50	150	300
400	500	0	-45	+105	+50	50	150	300
500	630	0	-50	+100	+50	50	150	300
630	800	0	-75	+150	+75	75	225	450



**Table 3. Four-row Bearing Roll Neck Fits (Inch Series)**

Unit :  $\mu\text{m}$

Nominal bearing bore diameter d (mm)				Single plane mean bore diameter deviation $\Delta d_s$		Roll neck diameter deviation		Fit clearance		Wear limit of roll neck (Reference)
Over		Incl.		High	Low	High	Low	Min	Max	
(mm)	(inch)	(mm)	(inch)							
127.000	5.0000	152.400	6.0000	+25	0	-120	-150	120	175	300
152.400	6.0000	203.200	8.0000	+25	0	-150	-175	150	200	400
203.200	8.0000	304.800	12.0000	+25	0	-175	-200	175	225	450
304.800	12.0000	609.600	24.0000	+51	0	-200	-250	200	301	600
609.600	24.0000	914.400	36.0000	+76	0	-250	-325	250	401	800

**Table 4. Four-row Bearing Chock Fits (Inch Series)**

Unit :  $\mu\text{m}$

Nominal bearing outside diameter D (mm)				Single plane mean outside diameter deviation $\Delta D_s$		Chock inside diameter deviation		Fit clearance		Wear limit of chock inside diamater (Reference)
Over		Incl.		High	Low	High	Low	Min	Max	
(mm)	(inch)	(mm)	(inch)							
-	-	304.800	12.0000	+25	0	+ 75	+ 50	25	75	300
304.800	12.0000	609.600	24.0000	+51	0	+150	+100	49	150	300
609.600	24.0000	914.400	36.0000	+76	0	+225	+150	74	225	450

# Spherical Roller Bearings

---

## Design and configurations

Spherical Roller Bearings are particularly suitable for applications where misalignment can arise from error in mounting or from shaft deflection.

NACHI Spherical Roller Bearings are manufactured in a number of design and material configurations depending on the type of application and size of the bearing.

See the [Table 1](#) for the roller, guide ring and cage design for NACHI Spherical Roller Bearings.

They can sustain radial and axial loads.

## Attention

- (1) For high axial load applications, the axial load  $F_a$  must not exceed 0.6 of the radial load  $F_r$ . If the axial load exceeds 0.6  $F_r$ , please contact NACHI engineers for design assistance.
- (2) For applications where oscillating loads (such as shaker screen applications) or high speed is involved, please contact NACHI for design assistance.
- (3) In very lightly loaded or no load conditions, sliding motion can occur which could damage the bearing.  
To prevent this damage, bearings must be subjected to a load greater than 0.02  $C_r$  (basic dynamic load rating).

[Table 1. Design and configurations](#)

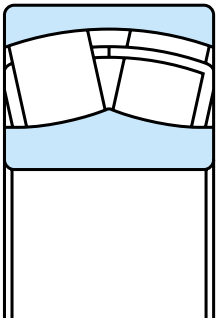
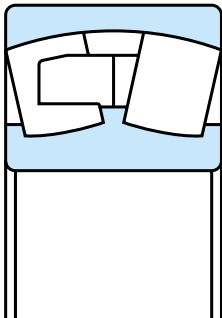
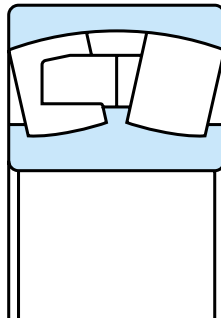
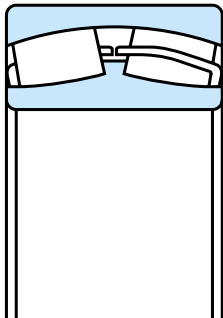

Table 1. Design and configurations

Suffix Series	EX	EX1	E	E2	E	AEX	AX	A2X	AX
239					20,26, 44~/1060		28~40		
230			20~36		38~/1000		20~36	38~48	
240		24~36			38~/800				24~36
231		22~34	20		36~/800		20~34	36~48	
241		22~32			36~/500				22~34
222	05~30		32	32	34~68	5~30		32	
232		18,20~30	16,17,19		32~/600		20~30	32~40	
213		11~22	04~10,24				6~22		
223	08~26				28~60	7~26		28,30	
Cross Section									
Roller	Symmetric			Symmetric		Asymmetric			Asymmetric
Center Guide	Floating Ring			Inner Ring Rib		Inner Ring Rib			Inner Ring Rib
Retainer	Pressed Steel			Machined Brass Mild Steel		Machined Brass			Pressed Brass



## Lubrication Holes and Groove

The outer ring of Spherical Roller Bearings are often made with lubrication holes and a groove for feeding lubricant. The outer ring may also be configured with oil holes only depending on fitting, mounting or service conditions.

## Heat-stabilized Bearings

NACHI Spherical Roller Bearings are subjected to a heat-stabilization treatment as standard.

They can be used at operating temperature of up to 200°C with minimal dimensional changes occurring.

**Table 2. Lubrication holes and groove**

Modification to outer ring	Suffix	Part No. Example
Lubrication holes and groove	W33	22210E W33
Lubrication holes	W20	22210E W20

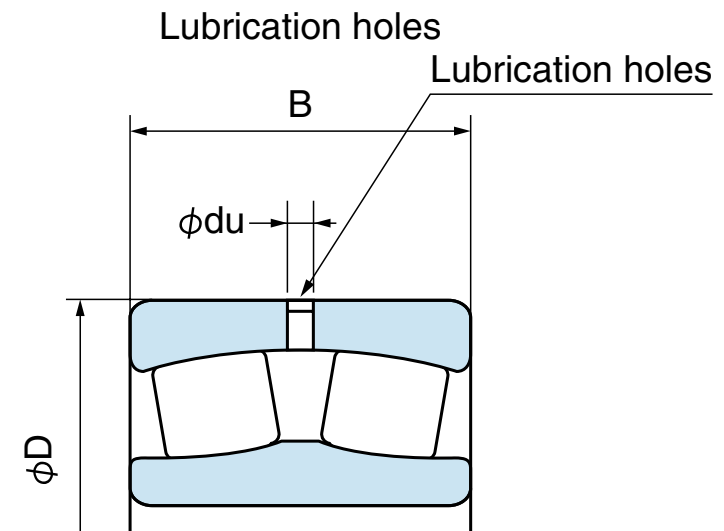
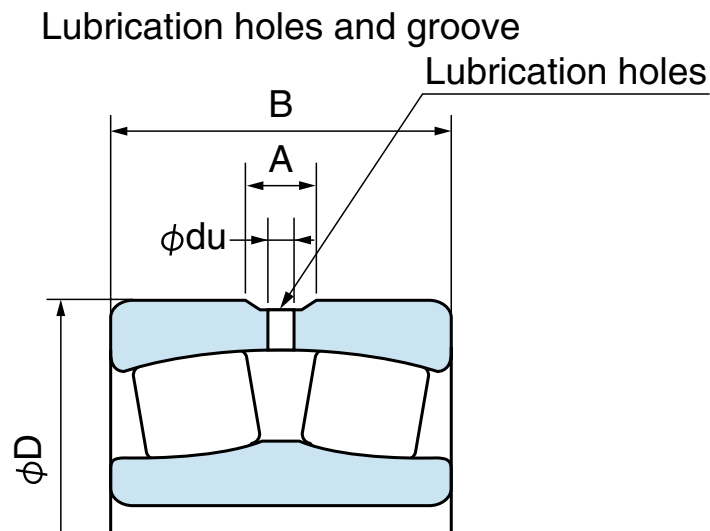



Table 3. Lubrication holes and groove dimensions

Outer ring width B (mm)		Series	23900		Others	
Over	Incl.		A	du	A	du
18	30		7	3	6	3
30	35		8	4	8	3 <sup>#1</sup>
35	40		8	4	8	4 <sup>#2</sup>
40	50		11	5	10	4 <sup>#3</sup>
50	65		12	6	11	5 <sup>#4</sup>
65	80		14	8	14	6 <sup>#5</sup>
80	100		18	10	18	8
100	120		24	12	20	10
120	160		28	15	26	12
160	200		35	20	32	15
200	250		40	20	40	20
250	315		45	25	45	20
315	400		50	25	50	25

Exceptions ; #1 : 22308 = 4, #2 : 21315 = 3,  
 #3 : 22219, 22220, 23022, 23024 = 5  
 #4 : 22317, 22318 = 6, #5 : 23036 = 8

Table 4. Standard Number of Lubrication holes

Nominal outside dia D (mm)		Number of lubrication holes
Over	Incl.	
—	180	4
180	250	6
250	315	6
315	400	6
400	500	6
500	—	8

Lubrication holes and groove

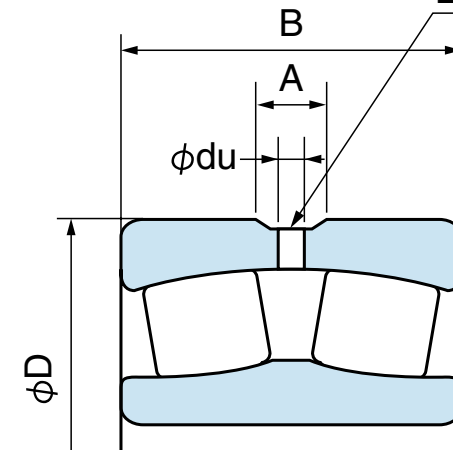



## Misalignment

Maximum permissible misalignment angle is about  $2^\circ$  under general service conditions.

But its angle will vary with the series, service condition and surrounding structure.

As rotational speed increases, misaligned bearings will tend to generate more noise.

Due to noise constraints, the practical maximum misalignment in a bearing may be considerably less than the maximum permissible misalignment.

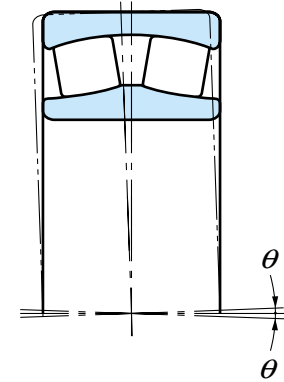

## Mounting bearings with tapered bore

Mounting bearings with a tapered bore requires some experience and technique.

Bearings with tapered bore are always mounted with an interference fit on the shaft.

To measure the amount of interference fit on the shaft, the axial displacement of the inner ring or the reduction of radial internal clearance due to the interference fit can be used. Generally, the measurement of reduction in radial internal clearance is a more reliable method than measurement of the axial displacement of the inner ring.

### [Table 5 Mounting Bearings with Tapered Bore](#)

Table 5 Mounting Bearings with Tapered Bore

(1/2)

Nominal bore diameter d		Radial clearance reduction		Axial displacement <sup>1)</sup>				Internal clearance after mounting <sup>2)</sup>		
				Taper				Min		
Over	Incl.	Max	Min	1 : 12	Max	1 : 30	Max	Normal	C3	C4
24	30	0.015	0.020	0.3	0.35	–	–	0.015	0.020	0.035
30	40	0.020	0.025	0.35	0.4	–	–	0.015	0.025	0.040
40	50	0.025	0.030	0.34	0.45	–	–	0.020	0.030	0.050
50	65	0.030	0.040	0.45	0.6	–	–	0.025	0.035	0.055
65	80	0.040	0.050	0.6	0.75	–	–	0.025	0.040	0.070
80	100	0.045	0.060	0.7	0.9	1.7	2.2	0.035	0.050	0.080
100	120	0.050	0.070	0.75	1.1	1.9	2.7	0.050	0.065	0.100
120	140	0.065	0.090	1.1	1.4	2.7	3.5	0.055	0.080	0.110
140	160	0.075	0.100	1.2	1.6	3.0	4.0	0.055	0.090	0.130
160	180	0.080	0.110	1.3	1.7	3.2	4.2	0.060	0.100	0.150
180	200	0.090	0.130	1.4	2.0	3.5	5.0	0.070	0.100	0.160
200	225	0.100	0.140	1.6	2.2	4.0	5.5	0.080	0.120	0.180
225	250	0.110	0.150	1.7	2.4	4.2	6.0	0.090	0.130	0.200
250	280	0.120	0.170	1.9	2.7	4.7	6.7	0.100	0.140	0.220
280	315	0.130	0.190	2.0	3.0	5.0	7.5	0.110	0.150	0.240

Note: 1) The values are applied for mounting on solid shaft. In case of hollow shaft, larger axial displacement should be applied.

2) In following cases, please make sure radial internal clearance after mounting.

- Initial radial clearance is less than (bore diameter deviation) × 0.5
- Temperature difference exists between inner ring and outer ring under operation.

Internal clearance after mounting must be over these values.





Table 5 Mounting Bearings with Tapered Bore

(2/2)

Nominal bore diameter d		Radial clearance reduction		Axial displacement <sup>1)</sup>				Internal clearance after mounting <sup>2)</sup>		
				Taper				Min		
Over	Incl.	Max	Min	1 : 12 Min	Max	1 : 30 Min	Max	Normal	C3	C4
315	355	0.150	0.210	2.4	3.3	6.0	8.2	0.120	0.170	0.260
355	400	0.170	0.230	2.6	3.6	6.5	9.0	0.130	0.190	0.290
400	450	0.200	0.260	3.1	4.0	7.7	10	0.130	0.200	0.310
450	500	0.210	0.280	3.3	4.4	8.2	11	0.160	0.230	0.350
500	560	0.240	0.320	3.7	5.0	9.2	12.5	0.170	0.250	0.360
560	630	0.260	0.350	4.0	5.4	10	13.5	0.200	0.290	0.410
630	710	0.300	0.400	4.6	6.2	11.5	15.5	0.210	0.310	0.450
710	800	0.340	0.450	5.3	7.0	13.3	17.5	0.230	0.350	0.510
800	900	0.370	0.500	5.7	7.8	14.3	19.5	0.270	0.390	0.570
900	1000	0.410	0.550	6.3	8.5	15.8	21	0.300	0.430	0.640
1000	1120	0.450	0.600	6.8	9.0	17	23	0.320	0.480	0.700
1120	1250	0.490	0.650	7.4	9.8	18.5	25	0.340	0.540	0.770

Note: 1) The values are applied for mounting on solid shaft. In case of hollow shaft, larger axial displacement should be applied.

2) In following cases, please make sure radial internal clearance after mounting.

- Initial radial clearance is less than (bore diameter deviation) × 0.5
- Temperature difference exists between inner ring and outer ring under operation.

Internal clearance after mounting must be over these values.



# Thrust Ball Bearings

## Design

Thrust Ball Bearings are made as single -direction and double-direction bearings. Single-direction Thrust Ball Bearings can sustain an axial load in only one direction, whereas Double-direction Thrust Ball Bearings can sustain bi-directional thrust load.

Both types of Thrust Ball Bearings cannot sustain a radial load.

Both Thrust Ball Bearings are available with aligning housing washers for mating with a housing having an aligning surface radius. Aligning seat washers with an aligning surface radius are also available for ease of design and mounting against a flat housing shoulder.

The Bearings with a polyamide cage are indicated suffix G at bearing number on package surface.

**Table 1. Bearing series**

Type	Flat back-face type	Spherical back-face type	With aligning seat
Single-direction	511	—	—
	512	532	532U
	513	533	533U
	514	534	534U
	29	—	—
	39	—	—
	O <sup>(1)</sup>	—	—
	TAM <sup>(2)</sup>	—	—
	TG <sup>(2)</sup>	—	—
Double-direction	522	542	542U
	523	543	543U
	524	544	544U

**Table 2**

Bearing series	Bore diameter No.
511	28 ~
512, 522, 532, 542	26 ~
513, 523, 533, 543	22 ~
514, 524, 534, 544	17 ~

Notes: (1) Series O is inch-dimensioned.

(2) Series TAM, TG is extra-small and miniature.





## Attention

- (1) Thrust Ball Bearings with flat housing washers do not permit any angular misalignment between shaft and housing, nor can they accommodate any error of angle between the support surfaces in the housing and on the shaft.
- (2) They are not suitable for high speed applications. Limiting speed are indicated in the dimension table.
- (3) The outside diameters of shaft washer and housing washer or center washer are the same, so clearance must be provided for the outside diameter of shaft washer or center washer by use of a step in the housing bore (See Fig.1). The outside diameter of the shaft washer or center washer of the bearings that are indicated in Table 2 are smaller than that of the housing washer, so no clearance step is required in the housing for the shaft (center) washer. See Fig.2.
- (4) Bearings with polyamide cage should be used less than 120°C.

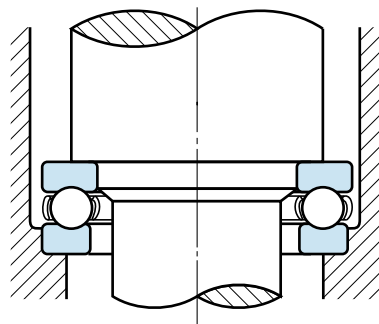

Single-direction

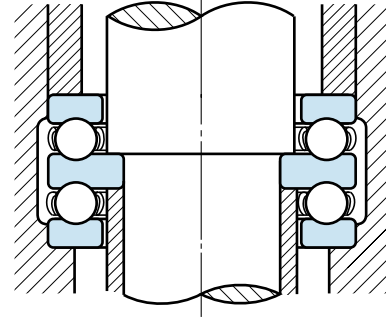

Double-direction

Fig 1

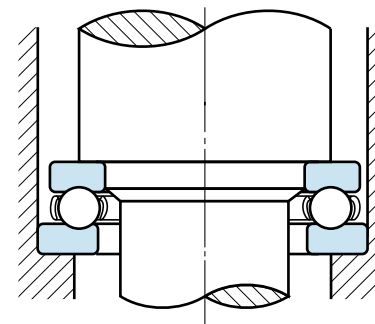

Single-direction

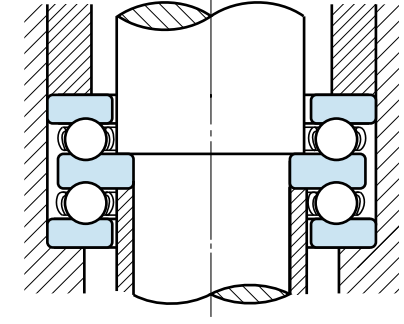

Double-direction

Fig 2





## Cage

Standard fitting cages are shown in Table 3. If other cages are necessary, please contact NACHI.

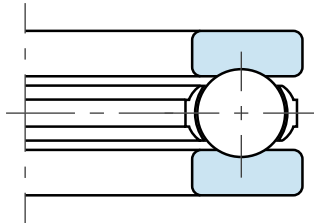

**Fig 3. Polyamide**

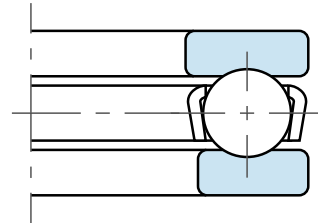

**Fig 4. Pressed Steel**

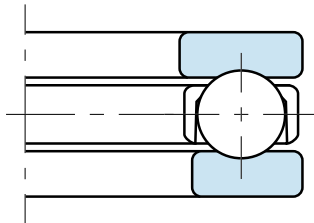

**Fig 5. Machined**

**Table 3. Cage of Thrust Ball Bearings**

Series	Diameter Number		
	Polyamide	Pressed Steel	Machined
511	00 ~ 07	08 ~ 52	56 ~ 72
512	01 ~ 07	00, 08 ~ 28	30 ~ 72
513	—	05 ~ 20	22 ~ 40
514	—	05 ~ 14	15 ~ 36
522	02 ~ 07	08 ~ 28	30 ~ 44
523	—	05 ~ 20	22 ~ 40
524	—	05 ~ 14	15 ~ 36
532	01 ~ 07	00, 08 ~ 28	30 ~ 72
533	—	05 ~ 20	22 ~ 40
534	—	05 ~ 14	15 ~ 36
542	02 ~ 07	08 ~ 28	30 ~ 44
543	—	05 ~ 20	22 ~ 24
544	—	05 ~ 14	15 ~ 20
29	—	00 ~ 22	23 ~ 28
39	—	05 ~ 24	—
0—	—	3 ~ 30	32 ~ 48
TAM	—	3 ~ 8 <sup>(1)</sup>	—
TG	—	5 ~ 8 <sup>(1)</sup>	—

Remarks 1. Basic load rating of dimension table are indicated in using cage of table 3.

Notes<sup>(1)</sup> Indicate bore diameter not bore number.





## Minimum axial load

When Thrust Ball Bearings are run at high speeds, the contact angle between the ball and the raceway in the radial plane is affected by the centrifugal force of the balls and the sliding movement between the balls and raceways are occurred. The sliding movement may cause damage as smearing. To prevent this damage, Thrust Ball Bearings must be subjected to a given load more than a minimum load from function (1) or (2).

Single-direction Thrust Ball Bearings can sustain only one direction axial load, so if bi-direction axial loads are present, Double-direction Thrust Ball Bearings must be used and preloaded by a load more than the minimum load.

In case of a vertical axis, shaft weight often exceeds the minimum load. In this case, the acting load may be decreased by the external axial load acting in the opposite direction.

$$F_{a \min} = K \cdot n^2 \quad \dots\dots\dots (1)$$

$$F_{a \min} = \frac{C_{oa}}{1000} \quad \dots\dots\dots (2)$$

Use the larger result of (1) or (2)

$F_{a \min}$  =Minimum axial load (N)

$K$  =Minimum axial factor

see Table 4

$n$  =Rotating speed(rpm)

$C_{oa}$  =Basic static load rating (N)

**Table 4. Minimum axial factor  $K$  ( $\times 10^{-6}$ )**

Table 4. Minimum axial factor K ( $\times 10^{-6}$ )

Series Bore No.	511	512, 522	513, 523	514, 524
00	1.03	1.55	—	—
01	1.26	1.92	—	—
02	1.56	3.36	—	—
03	1.84	4.09	—	—
04	3.42	7.33	—	—
05	7.19	13.1	20.4	43.8
06	9.36	17.2	33.1	81.4
07	11.2	32.8	58.3	128
08	20.4	49.7	97.2	221
09	24.6	57.9	138	316
10	29.3	66.8	211	440
11	44.6	133	326	656
12	64.7	160	375	956
13	72.0	179	428	1240
14	82.8	200	596	1580
15	94.3	222	808	1800
16	103	245	907	2230
17	116	359	1240	2740
18	187	528	1390	4320
20	363	850	1850	4790
22	423	1010	2740	8220

Series Bore No.	511	512, 522	513, 523	514, 524
24	488	1130	4130	9980
26	648	1940	5140	16100
28	782	2150	6330	16900
30	886	2490	7140	25800
32	997	2880	9960	30000
34	1420	3940	11100	40100
36	1540	4330	15800	46330
38	2340	6290	23100	—
40	2520	6880	29700	—
44	3000	8130	—	—
48	4900	15900	—	—
52	5580	18400	—	—
56	9800	20400	—	—
60	14600	38000	—	—
64	16400	41800	—	—
68	18300	45700	—	—
72	20300	75600	—	—



Table 4. Minimum axial factor K ( $\times 10^{-6}$ )

(2/2)

Series Bore No.	29	39
00	1.55	—
01	1.92	—
02	2.64	—
03	3.30	—
04	3.82	—
04 1/2	6.41	—
05	7.51	14.2
06	9.72	28.9
07	20.1	52.3
08	25.1	81.0
09	31.6	140
10	46.1	209
11	54.4	284
12	60.7	350
13	86.0	426

Series Bore No.	29	39
14	99.5	556
15	114	704
16	152	927
17	172	1210
18	187	1580
19	286	2010
20	321	2090
21	346	2390
22	361	3220
23	350	3940
24	538	4500
25	498	—
26	—	—
27	—	—
28	794	—

Series Bore No.	O –
3	1.34
4	3.62
5	4.65
6	6.40
7	7.76
8	9.24
9	11.6
10	16.5
11	19.0
12	23.0
13	21.0
14	31.3
15	42.1
16	46.9
17	75.0

Series Bore No.	O –
18	82.8
19	110
20	121
21	132
22	176
23	204
24	223
26	350
28	395
30	431
32	580
36	1100
40	1730
44	2840
48	3690

# Spherical Roller Thrust Bearings

Because there are many sliding surfaces in Spherical Roller Thrust Bearings (cage-to-guide-sleeve and roller-ends-to-rib), oil lubricant (not grease) should be used.

## Aligning angle

Maximum permissible misalignment angle is about  $2^\circ$  under general service conditions. If the aligning advantages of this bearing type are to be realized, care must be taken to provide clearance for parts in the surrounding structure.

The safety-factor "So" must be over 4.

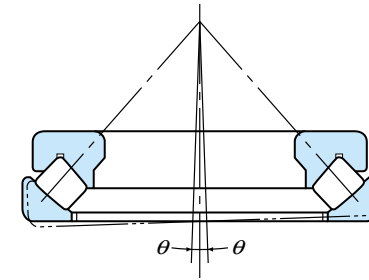

## Minimum axial load

To prevent damage caused by sliding motion between the rollers and raceway, spherical roller thrust bearings must be subjected to a load more than the minimum load,  $F_{a \min}$ .

$$F_{a \min} = \frac{C_{0a}}{1000}$$

# Precision Machine Tool Bearings

Bearings selected for use in machine tools are required to have designs which will ensure high rotational speed and accurate output.

## Bearings for Machine Tool Spindles

Spindle bearings are generally classified as those that support radial load and those that support thrust loads.

**Fig 1.**  
The bearings  
for radial load

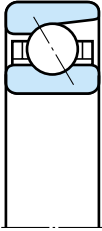
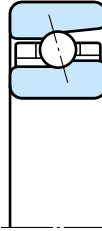
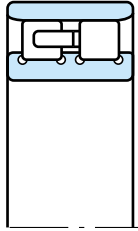
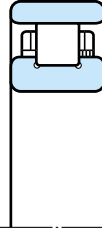
Angular Contact Ball Bearings		Cylindrical Roller Bearings	
			
70B, 70C 72B, 72C	BNH000	NN30 NN30K	N10 N10K

**Fig 2.**  
The bearings  
for axial load

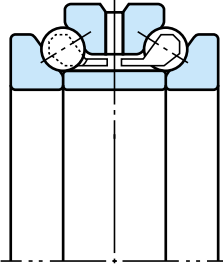
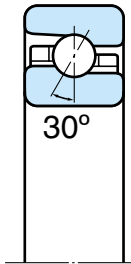
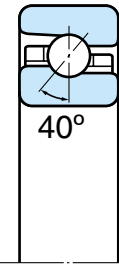
Double-direction Thrust Angular Contact Ball Bearings	Combination Angular Contact Ball Bearings	
		
TAD20	TAH10T	TBH10T







# High-speed Angular Contact Ball Bearings Type BNH000

## Feature design

Type BNH000 bearings are designed with smaller balls than Angular Contact Ball Bearings Type C. They are suitable for high-speed applications and lower heat generation and are typically used in high speed machining center spindles.

(Their tolerance class is JIS (ISO) class 4 normally.)

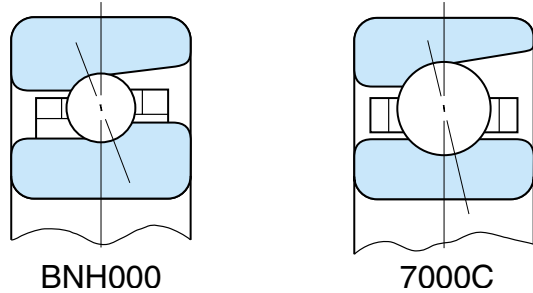

## Bearing No.

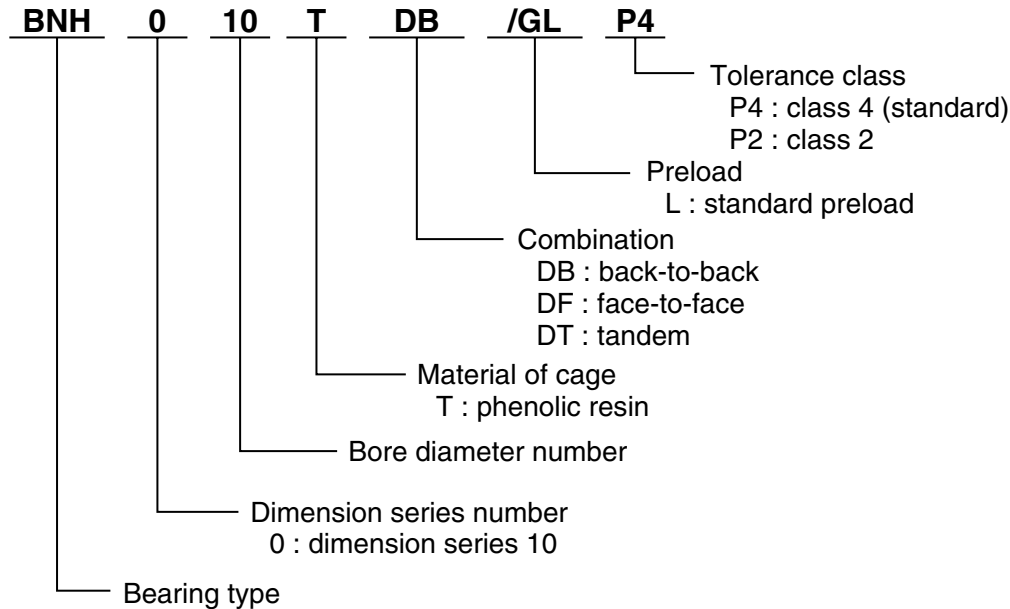

## Standard preload

Standard preload of BNH type is designed with light preload.

Unit : N

Bore Diameter Number	BNH000
07	78.5
08	
09	98.1
10	
11	
12	147
13	
14	
15	245
16	
17	294
18	
19	392
20	
21	490
22	
24	588
26	
28	785
30	
32	1080
34	
	1180
	1370

Note: For DB or DF combination





## Combination Angular Contact Ball Bearings Type TAH10, TBH10

### Feature design

The ball diameter and quantity are the same as Double-direction Thrust Angular Contact Ball Bearings type TAD20. The contact angle is 30° for TAH10 type and 40° for TBH10 type. They are suitable for high-speed.

Their Duplex Combination width 2B of type DB or DF is the same as width B<sub>1</sub> of TAD20 type. TAD20 type are interchangeable to TAH10 type or TBH10 type by changing the method of setting to shaft.

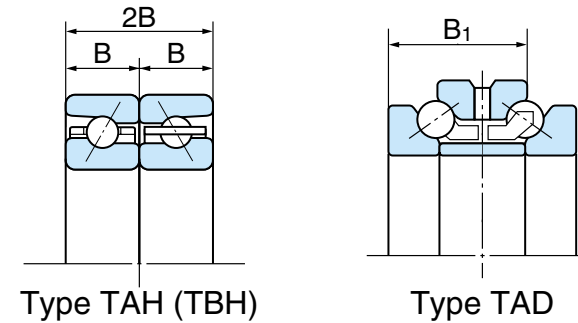

### Tolerance of outside diameter

The outside diameter of the outer ring is made with a special tolerance for a clearance fit in the housing.

This enables the associated radial bearing to carry a radial load, like as TAD20 type.

### Tolerance of outside diameter

Unit :  $\mu\text{m}$

Nominal bearing outside diameter D (mm)		Outside diameter deviation $\Delta D_s$	
Over	Incl.	High	Low
30	50	-20	-41
50	80	-30	-49
80	120	-36	-58
120	180	-43	-68
180	250	-50	-79
250	315	-56	-88

JIS (ISO) class 4 for other tolerances



[Continue→]



Standard preload

Unit : N

Bore Diameter Number	TAH	TBH
50	294	539
55		
60	392	686
65		
70	588	1080
75		
80	686	1270
85		
90		
95	1080	1860
100		
105	1180	2060
110	1370	2450
120	1470	2550
130	1860	3330
140	1960	3530
150	2450	4310
160	2650	4510
170	3040	5300

Bearing No.

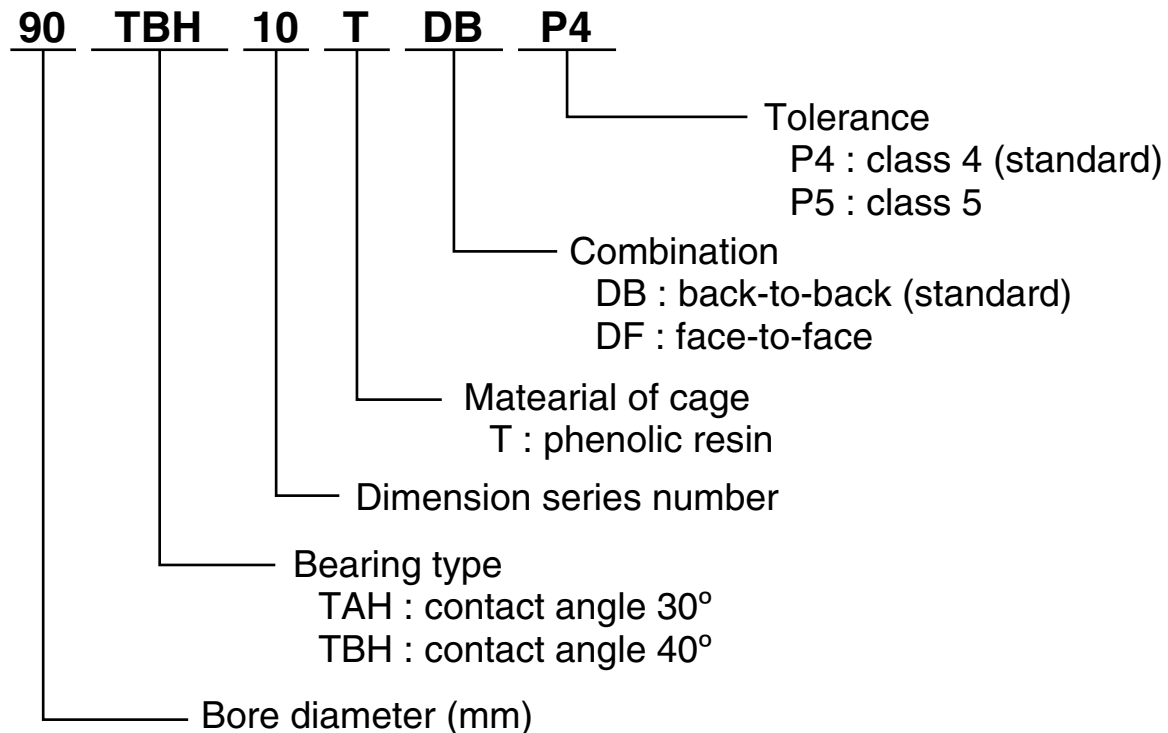

Note: For DB or DF combination



# Double-direction Thrust Angular Contact Ball Bearings Type TAD20

## Feature design

This is a two-row bearing with a one-piece outer ring. The ball assembly is arranged as a back-to-back, Angular Contact Ball Bearings with a high contact angle. This type is used as the Axial Load Bearing in conjunction with a Double-row Cylindrical Roller Bearings.

## Bearing No.

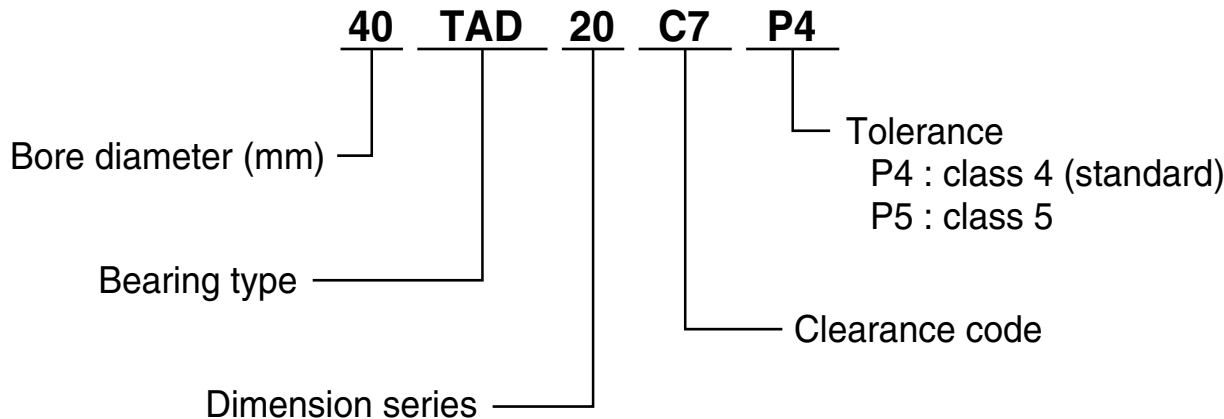

## Standard preload

Bore Diameter Number	Preload (N)	
	C7	C8
20TAD20	215	590
30TAD20	245	
35TAD20		
40TAD20	295	785
45TAD20	345	880
50TAD20		
55TAD20	390	980
60TAD20	590	1250
65TAD20		1350
70TAD20	685	1750
75TAD20		
80TAD20		2150
85TAD20	1050	2850
90TAD20	1150	2950
95TAD20		
100TAD20	1450	3450
105TAD20		
110TAD20		4400
120TAD20	1650	4700
130TAD20	1750	
140TAD20	1950	6350
150TAD20	2750	6850
160TAD20		
170TAD20	2950	8800
180TAD20	3900	11800
190TAD20		
200TAD20	4100	

[Continue→]

**Tolerance**

The outer ring is made with a negative tolerance for a clearance fit in the housing.  
This enables the associated radial bearing to carry a radial load.

**Inner Ring and Height Tolerances**Unit :  $\mu\text{m}$ 

Nominal bearing bore diameter d (mm)		Single plane mean bore diameter variation $\Delta d_{mp}$				Variation of assembled height T		Width variation of inner ring $V_{BS}$ (Max)		Side face runout with reference to bore $S_d$ (Max)		Side face runout with reference to raceway of assembled bearing inner ring and of assembled bearing outer ring $S_{ia}$ $S_{ea}$ (Max)	
		Class 5		Class 4									
		Over	Incl.	High	Low								
18	30	0	-6	0	-5	0	-300	5	2.5	8	4	5	3
30	50	0	-8	0	-6	0	-400	5	3	8	4	5	3
50	80	0	-9	0	-7	0	-500	6	4	8	5	6	5
80	120	0	-10	0	-8	0	-600	7	4	9	5	6	5
120	180	0	-13	0	-10	0	-700	8	5	10	6	8	6
180	250	0	-15	0	-12	0	-800	10	6	11	7	8	6

**Variation and deviation of outer ring**Unit :  $\mu\text{m}$ 

Nominal bearing bore diameter D (mm)		Single plane mean outside diameter variation of outer ring $\Delta D_{mp}$		Width deviation of outer ring $V_{CS}$ (Max)		Outside inclination of outer ring $S_d$ (Max)	
		Class 5	Class 4				
		High	Low				
18	30	-20	-27	5	2.5	8	4
30	50	-24	-33	6	3	8	4
50	80	-28	-38	8	4	9	5
80	120	-33	-44	8	5	10	5
120	180	-33	-46	8	5	10	5
180	250	-37	-52	10	7	11	7
250	315	-41	-59	11	7	13	8





## Flanged-cup Tapered Roller Bearings

This bearing permits a simplified housing design. It is made with high precision (JIS (ISO) class 5 or 4) for applications such as machine tool spindles.

### Deviation of flange outside diameter Df Unit : $\mu\text{m}$

Df (mm)		Deviation	
Over	Incl.	High	Low
30	50	0	- 62
50	80	0	- 74
80	120	0	- 87
120	180	0	-100
180	250	0	-115
250	315	0	-130

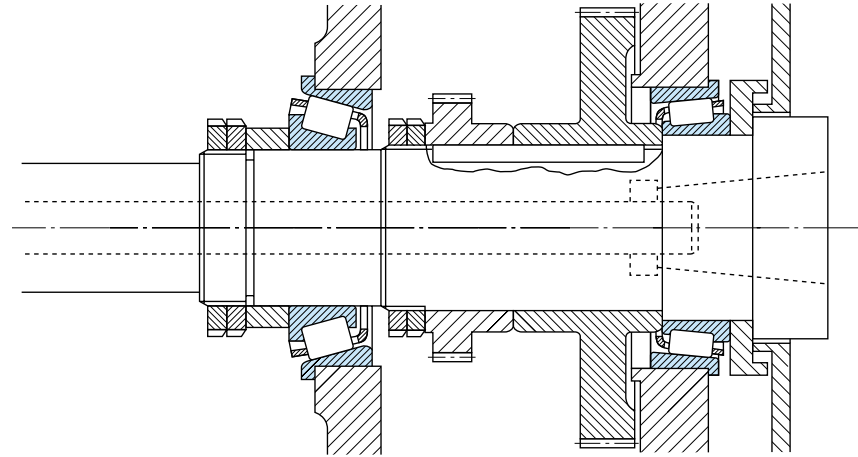

Example of mounting of Flanged-cup Tapered Roller Bearings





## Cross Tapered Roller Bearings

This bearing type is designed with two inner rings and one outer ring. The rolling elements (Tapered rollers) are arranged with their surfaces contact the ring raceways in an alternating pattern.

### Feature design

- This type can sustain radial, overturning moment and bi-directional axial loads.
- Change in size due to thermal growth does not affect this type of bearing. Preload is stable over the entire temperature operating range.
- Light weight, compact, easy to assemble.

### Applications

- Worktable of machining centers or vertical grinding machines
- Work-spindle of lathes or grinding machines
- The indexing mechanisms of large milling machines or drilling machines
- Turntable mechanism of parabolic antenna

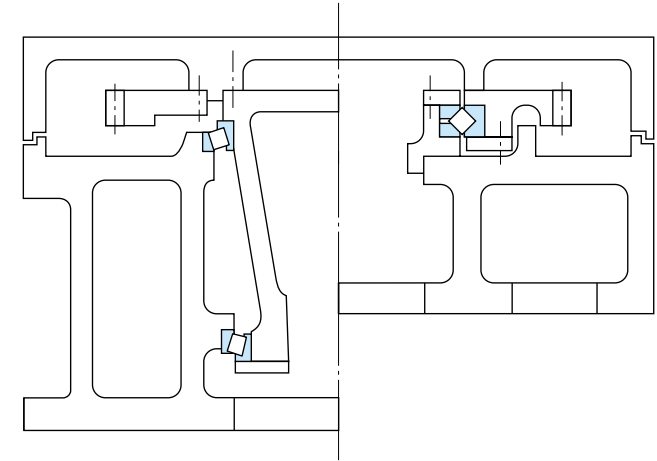

Example of mounting of Tapered Roller Bearings and Cross Tapered Roller Bearing



[Continue→]



## Tolerances

Unit :  $\mu\text{m}$ 

Bearing No.	Single plane mean bore diameter variation $\Delta d_{mp}$		Single plane mean outside diameter variation of outer ring $\Delta D_{mp}$		Variation of assembled height T		Outer ring runout Max	
	High	Low	High	Low	High	Low	Radial runout	Sideface runout
200XRN28	0	-15	0	-18	+350	-250	7	7
250XRN35	0	-10	0	-13	+350	-250	9	9
300XRN40	0	-13	0	-15	+350	-250	7	7
350XRN47	0	-13	0	-15	+350	-250	9	9
400XRN55	0	-13	0	-18	+350	-250	9	9
0457XRN060	+25	0	+25	0	+380	-380	9	9
580XRN76	+25	0	+38	0	+406	-406	10	10
600XRN83	+38	0	+38	0	+406	-406	12	12
0685XRN091	+38	0	+38	0	+508	-508	12	12
0901XRN112	+51	0	+51	0	+508	-508	14	14
1028XRN132	+76	0	+76	0	+760	-760	16	16



[Continue→]



### Axial Load and Axial Displacement

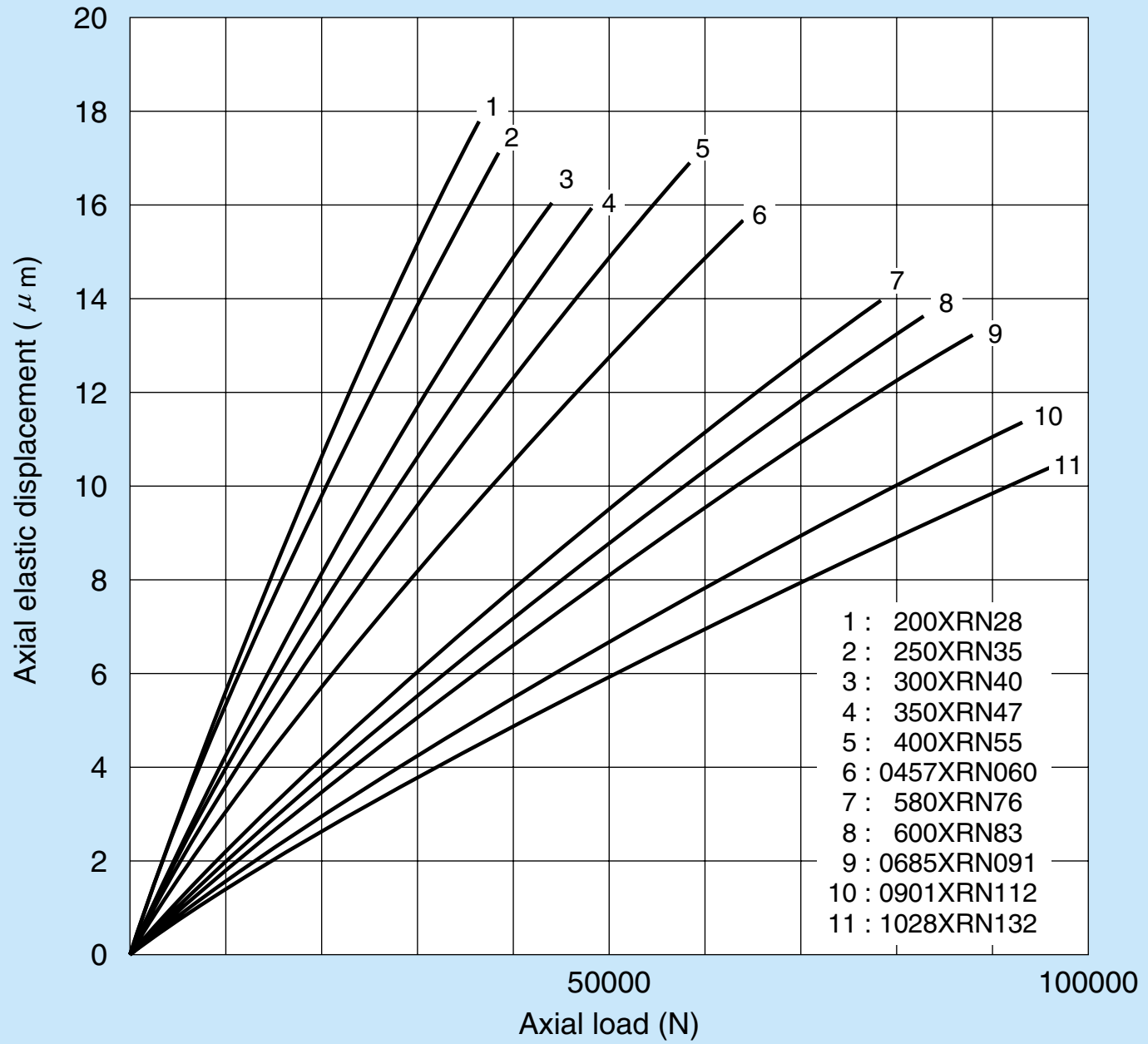



## Ball Screw Support Bearings

This type is used for supporting the ball screws that are used as actuators of high precision and high speed machines, precision measurement equipment, robots, etc.

This is a precision and high ability bearing.

### Feature design

- High stiffness

These bearings are designed with polyamide cages and a greater number of balls than conventional angular contact ball bearings. For these reasons, bearing stiffness is greater than conventional bearings.

- Easy fitting and adjustment

These bearings are supplied with a pre-set preload so difficult adjustment and torque measurement is eliminated.

- Simplified bearing mounting structure

These bearings are supplied with a 60° contact angle so radial and thrust load combinations can be sustained. This results in a simplified and compact shaft and housing design.

### Flush ground set combinations (Universal matching)

Flush ground set combination bearings are also available with a suffix U. This permits the use of random combinations where two or more bearings are mounted.

### 30 TAB 06 U / GM P4

└ Flush ground

Duplex sets

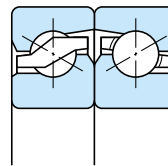

DF

Triplex sets

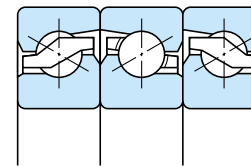

BFF

Quad sets

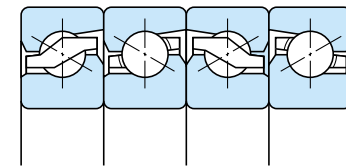

BBFF

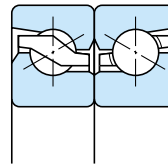

DB

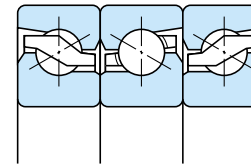

FFB

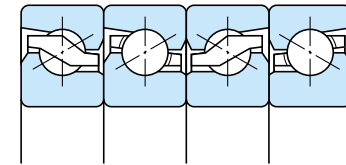

FFBB

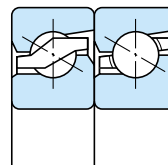

DT

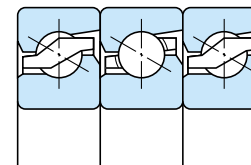

FFF

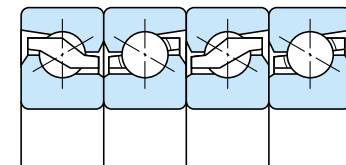

FFFB

[Continue→]





### Tolerances for inner ring

Unit :  $\mu\text{m}$

Nominal bearing bore diameter (mm)		Single plane mean bore diameter variation $\Delta d_{mp}$ $\Delta d_s$				Bore diameter variation in a single radial plane $V_{db}$ (Max)		Mean bore diameter variation $V_{dmp}$ (Max)		Deviation of a single inner ring width (or a single outer ring width) $\Delta B_s$ ( $\Delta C_s$ ) <sup>(1)</sup>				Width deviation of inner ring $V_{BS}$ (Max)		Radial runout of assembled bearing inner ring $K_{ia}$ (Max)		Side face runout $S_d$ with reference to bore (Max)		Side face runout with reference to raceway of assembled bearing inner ring $S_{ia}$ and outer ring $S_{ea}$ (Max)	
		P5		P4		P5	P4	P5	P4	P5		P4		P5	P4	P5	P4	P5	P4	P5	P4
Over	Incl.	High	Low	High	Low					High	Low	High	Low								
10	18	0	-5	0	-4	4	3	4	3	0	-80	0	-80	5	2.5	4	2.5	7	3	4	2
18	30	0	-6	0	-5	5	4	5	4	0	-120	0	-120	5	2.5	4	3	8	4	5	2.5
30	50	0	-8	0	-6	6	5	6	5	0	-120	0	-120	5	3	5	4	8	4	6	2.5
50	60	0	-9	0	-7	7	6	7	6	0	-150	0	-150	6	4	5	4	8	5	7	2.5

Note: (1) These deviations are for single bearing. For combination bearings, multiply these values by row number.

### Tolerances for outer ring

Unit :  $\mu\text{m}$

Nominal bearing outside diameter (mm)		Single plane mean outside diameter variation of outer ring $\Delta D_{mp}$ $\Delta D_s$				Outside diameter variation in a single radial plane $V_{Db}$ (Max)		Mean outside diameter variation $V_{Dmp}$ (Max)		Width deviation of outer ring $V_{Cs}$ (Max)		Radial runout of assembled bearing outer ring $K_{ia}$ (Max)		Outside inclination of outer ring $S_D$ (Max)	
		P5		P4		P5	P4	P5	P4	P5	P4	P5	P4	P5	P4
Over	Incl.	High	Low	High	Low										
30	50	0	-7	0	-6	5	5	4	3	5	2.5	7	5	8	4
50	80	0	-9	0	-7	7	5	5	3.5	6	3	8	5	8	4
80	120	0	-10	0	-8	8	6	5	4	8	4	10	6	9	5



**Shaft and housing tolerance:**

①For the fit, refer to the following table.

Shaft fit	j5
Housing fit	H6

②For the squareness of a shoulder, refer to the following table.

Dimensions of shaft diameter and housing bore diameter (mm)		Squareness ( $\mu\text{m}$ )
Over	Incl.	
—	80	4
80	120	5

**Preload and Axial Spring Constant**Unit :  $\mu\text{m}$ 

Bearing No.	Preload M (N)				Axial Spring Constant (N/ $\mu\text{m}$ )			
	DF DB	BFF FFB	BBFF FFBB	BFFF FFFB	DF DB	BFF FFB	BBFF FFBB	BFFF FFFB
15TAB04	2160	2940	4310	3430	735	1080	1470	1320
17TAB04	2160	2940	4310	3430	735	1080	1470	1320
20TAB04	2160	2940	4310	3430	735	1080	1470	1320
25TAB06	3330	4510	6670	5200	981	1470	1960	1910
30TAB06	3330	4510	6670	5200	981	1470	1960	1910
35TAB07	3920	5300	7840	6180	1230	1770	2350	2300
40TAB07	3920	5300	7840	6180	1230	1770	2350	2300
40TAB09	5200	7060	10400	8140	1320	1910	2550	2500
45TAB07	4120	5590	8240	6470	1270	1910	2550	2500
45TAB10	5980	8140	12000	9410	1470	2160	2890	2790
50TAB10	6280	8530	12600	9810	1520	2260	3040	2940
55TAB10	6280	8530	12600	9810	1520	2260	3040	2940
55TAB12	7060	9610	14100	11100	1770	2550	3480	3380
60TAB12	7060	9610	14100	11100	1770	2550	3480	3380



[Continue→]



### Axial Load and Axial Displacement

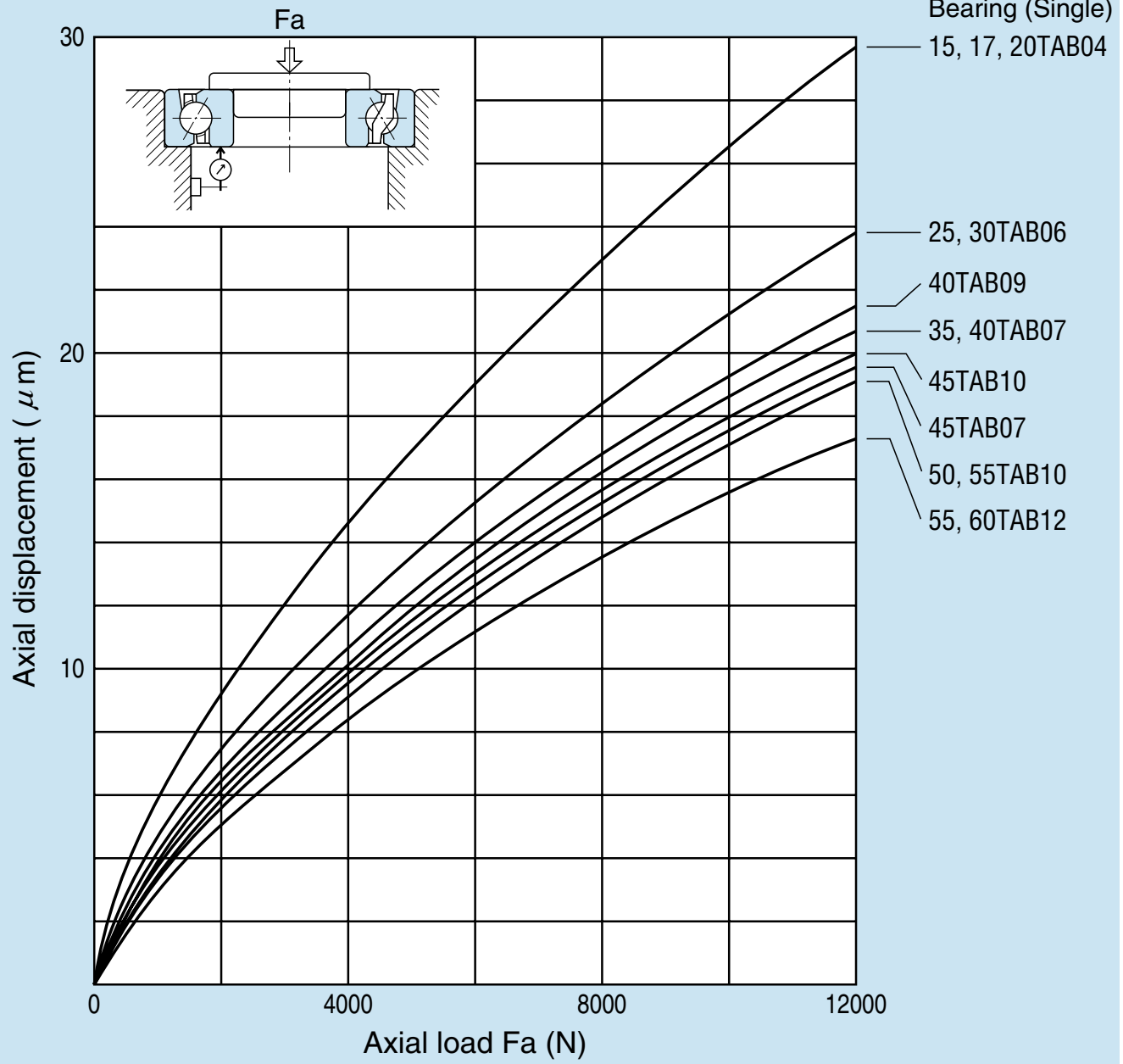

# Automotive Bearings

---

Many standard rolling bearings are used in automotive applications.

These standard bearings comply with JIS (or ISO) specifications and are shown in other sections of this catalog.

There are a number of types of bearings designed specifically for use in automotive applications. Bearings manufactured by NACHI for automotive applications include bearings for:

- Car Air Conditioning
- Magnetic Clutches
- Clutch-releases (drive train)
- King Pins
- Water Pumps
- Universal Joints
- Steering sectors
- Transmissions
- Wheel Assemblies

This catalog contains description of Wheel Assembly bearings, Self-aligning Clutch-release Bearings and Double-row Angular Contact Ball Bearings for Car Air Conditioning Magnetic Clutch. When using them, please consult NACHI about operating conditions and environment.

## Wheel Assembly Bearings

There are two types of Wheel Assembly Bearings; the 1st generation and the 2nd generation. The 1st has no flange, and the 2nd has a flange on the outer ring or inner ring.

Two types of the 1st generation are available, open type and contact seal type. The 2nd generation has the advantage of easy mounting and light weight.

## Self-aligning Clutch-release Bearings

The bearings are a combination clutch-release bearing and release-hub. They have the advantage of reliability, easy mounting and light weight.

These bearings are classified into inside fork guide type and outside fork guide type according to the fork lever types.

## Double-row Angular contact Ball Bearings for Car Air Conditioning Magnetic Clutch

They can be used at a high temperature and high speed. They have higher performance seals for dust ingress prevention and waterproof, and contain long life greases to operate under vibration conditions.

# Bearings for Rolling Stock

---

Various types of bearings are used as "rolling stock" bearings in railway axle-boxes. Cylindrical Roller Bearings and Tapered Roller Bearings are currently the bearing types most often favored for use since they can sustain high loads and provide excellent reliability.

## Journal Bearings

Double-row Cylindrical Roller Bearings or Double-row Tapered Roller Bearings for Journal applications are used for each of their capabilities. Cylindrical Roller Bearings are mostly used for easy maintenance and adaptability of high-speed. But in recent years, Tapered Roller Bearings are often used for adaptability of high-speed and long life without overhaul.

JIS(ISO) standard bearings are generally not used in journal bearing applications due to limited space and large load.

Journal bearings are specially designed wider bearings.

Cylindrical Roller bearings without a rib on the inner ring are used with the JB series Ball Bearings that handle axial loads.

Sealed Tapered Roller Bearings and sealed Cylindrical Roller Bearings with side ribs on the inner ring to carry thrust loads can be used for extended periods without overhaul. For this reason sealed bearings are used more often recently.

Bearings with a prefix JC, JT and JB are made to the specifications of Japan Railway Companies. A FCD type is made to NACHI design standards.

## Bearings for Gear box

These are bearings for a gearwheel and a pinion. They are mostly Tapered Roller Bearings, because they can sustain radial and large axial loads. They are lubricated with high viscosity gear oil, so the bearings for a pinion application are usually designed specially to prevent seizure at lower temperature. Also these bearings have been specially designed to withstand the severe vibration conditions which are normally found in this type application.

QT type bearings are made to the specifications of Japan Railway Companies, a ED type is made to NACHI design standards.

## Bearings for Traction motor

For traction motor, Deep-groove Ball Bearings and Cylindrical Roller Bearings without inner ring ribs are usually used together. These bearings have been specially designed to withstand high speed in grease lubrication and the severe vibrational load conditions.

NACHI bearing numbers for the traction motor applications have suffix JT for Deep-groove Ball Bearings and T, TS, or TSL for Cylindrical Roller Bearings.

## Special designs

Contact NACHI for the availability of other sizes.

# Sheave Bearings

This bearing type is designed as a double-row, full complement Cylindrical Roller bearing with ribs on both inner and outer rings. These bearings will sustain heavy radial load, and will handle moment load and will also take some axial load. Sheave bearings are suitable for a wide variety of uses in addition to sheaves. They are used for hoisting drum and wheel applications, and other applications which operate under heavy load at low speed.

Bearing series	Description
E50, E50...NR, E50...NRNT	This bearing series is designed for sheave application. It is a sealed (shield or seal) bearing and has a surface coating. The E50 series is made with two shields. The E50...NR and E50...NRNT have two snap rings in the outer ring. Series E50...NR is made with two shields, while the series E50...NRNT is made with two rubber seals.
RB48, RC48 RB49, RC49	These bearings are designed for general use. When mounting two or more bearings on an axle, the RB type should be used as a fixed side bearing and the RC type used as a free side bearing.







## Deviation of bore diameter and bearing width

Unit :  $\mu$  m

Nominal bearing bore diameter d (mm)		Deviation of d		Deviation of B	
Over	Incl.	High	Low	High	Low
30	50	0	-12	0	-120
50	80	0	-15	0	-150
80	120	0	-20	0	-200
120	150	0	-25	0	-250
150	180	0	-25	0	-250
180	250	0	-30	0	-300
250	315	0	-35	0	-350
315	400	0	-40	0	-400
400	500	0	-45	0	-450

Note: Tolerances are values before coating

## Deviation of outside diameter of outer ring

Unit :  $\mu$  m

Nominal bearing outside diameter D (mm)		Deviation of D	
Over	Incl.	High	Low
30	50	—	—
50	80	0	-13
80	120	0	-15
120	150	0	-18
150	180	0	-25
180	250	0	-30
250	315	0	-35
315	400	0	-40
400	500	0	-45
500	630	0	-50
630	800	0	-75

Note: Tolerances are values before coating





## Radial Clearance of Series 5000

Unit :  $\mu\text{m}$ 

Nominal bearing outside diameter D (mm)		Standard radial clearance	
Over	Incl.	Low	High
	70	35	70
70	80	40	75
80	100	45	90
100	125	55	105
125	150	65	115
150	180	65	120
180	240	65	130
240	280	70	135
280	310	70	140
310	340	75	150
340	360	90	165
360	420	100	180
420	460	110	195
460	520	125	215
520	600	140	235
600	650	155	275
650	700	180	300

## Radial Clearance of Series 4800/4900

Unit :  $\mu\text{m}$ 

Nominal bearing outside diameter D (mm)		Standard radial clearance	
Over	Incl.	Low	High
	70	40	75
70	80	40	75
80	100	45	90
100	125	55	105
125	150	65	115
150	180	65	120
180	240	65	130
240	280	70	135
280	310	70	140
310	340	75	150
340	360	90	165
360	420	100	180
420	500	110	195

# Ball Bearing Units

---

Ball Bearing Units offer a convenient method of applying highly reliable rolling contact bearings to applications without the necessity of manufacturing a bearing housing.

Generally Ball Bearing Units have following features.

- Self-aligning capability
- Sealed
- Easy to mount and dismount
- Interchangeability with foreign made units
- Many types suitable for applications Additionally NACHI Ball Bearing Units have the advantages of easy to use and high reliability.
- Anti-rotation pin on outer ring
- Eccentric collar type is also available
- Base for mount locating pin

Since Ball Bearings for units have the same geometry as deep groove ball bearing, load rating, reliability and other functions are equal with them of deep-groove ball bearing.





# 1. Designations

Number arrangement of Bearing Units and Ball bearings is shown as follows.

## (1) Bearing Unit Numbers

**C UK P 210 C CT4HR5 +H2310**

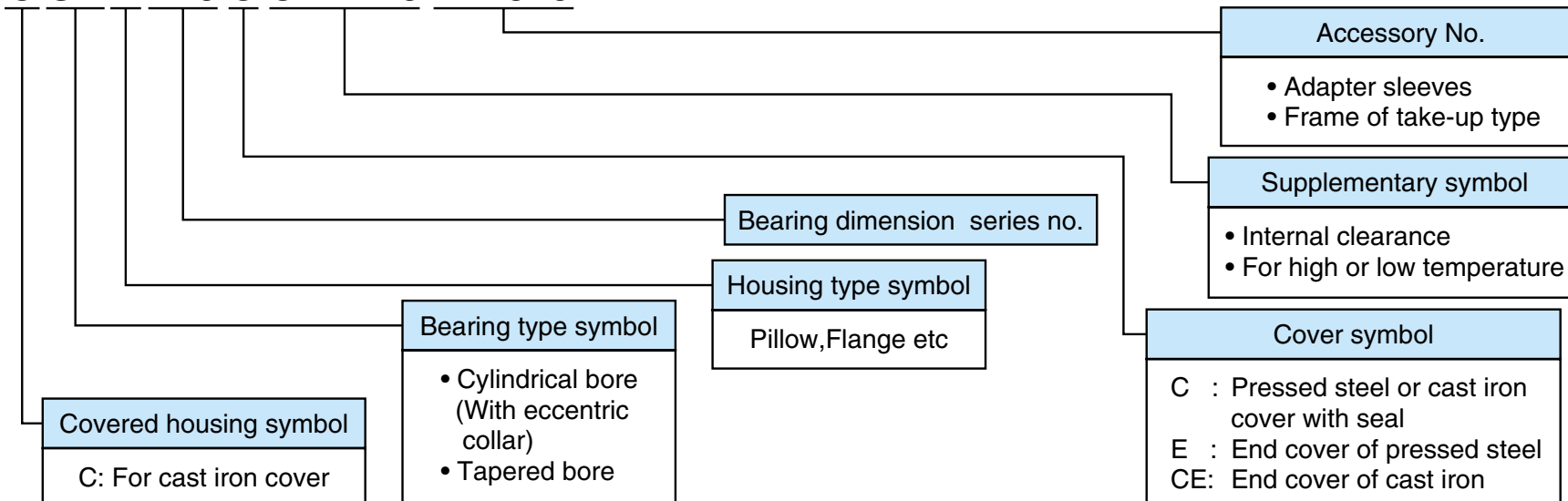

## (2) Ball Bearing Numbers

**UG 208 C3HR4 +ER**

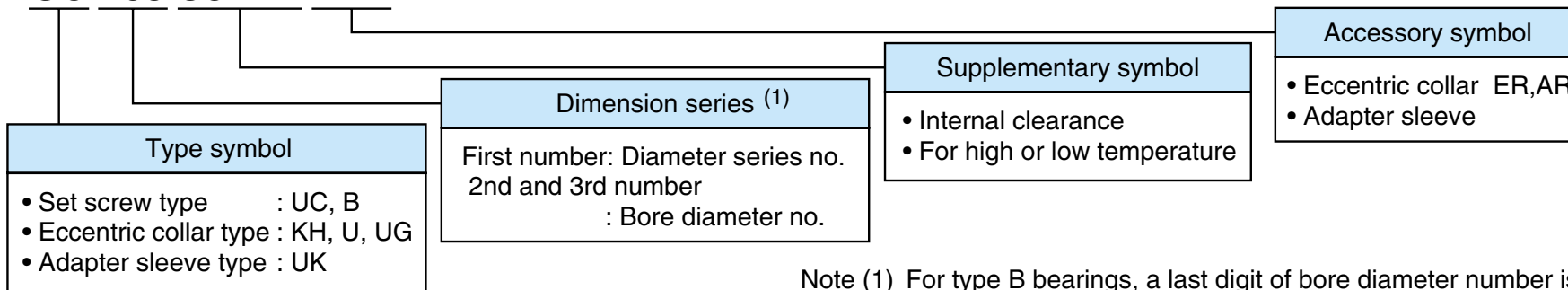

Note (1) For type B bearings, a last digit of bore diameter number is used as dimension series number.





## 2.Tolerance

Tolerances for ball bearings and housings are shown as follows.

### (1) Ball Bearing Tolerances

Tolerances of inner ring	Cylindrical bore : See <a href="#">Table 1</a> Tapered bore : See <a href="#">Table 5.7.1</a> (Technical Information) 1/12 taper bore
Tolerances of outer ring	Tolerance class 0 of <a href="#">Table 5.1.2</a> (Technical Information) Note : The lower limit of $\Delta D_{mp}$ is not applied within a distance of 1/4 of outer ring width from side faces.
Chamfer dimensions	See <a href="#">Table 2</a>

### (2) Bearing Unit Housing Tolerances

Spherical bearing seating of cast iron housing	See <a href="#">Table 3</a>
--	-----------------------------



Table 1. Tolerance of Inner Ring (Cylindrical bore)

Bore dia. Nominal d (mm)		Single plane mean bore dia. deviation $\Delta d_{mp}$		Bore dia. variation in a single radial plane $Vd_p$	Deviation of a single inner ring width $\Delta B_s$		Radial runout of assembled bearing inner ring $K_{ia}$ (reference)	Deviation of <sup>(1)</sup> eccentric value of inner ring eccentric face $\Delta H_s$
Over	Incl.	High	Low	Max	High	Low	Max	
6	10	+12	0	8	0	-120	15	$\pm 100$
10	18	+15	0	10	0	-120	15	$\pm 100$
18	31.75	+18	0	12	0	-120	18	$\pm 100$
31.75	50.8	+21	0	14	0	-120	20	$\pm 100$
50.8	80	+24	0	16	0	-150	25	$\pm 100$
80	120	+28	0	19	0	-200	30	—
120	180	+33	0	22	0	-250	35	—

Note (1) This deviation is used on the eccentric locking collar type bearings.

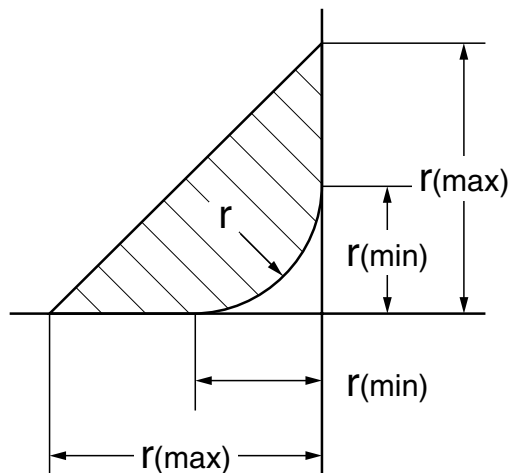

Remark The exact shape of the chamfer is not specified, but its contour will be in the area shown with oblique lines.

**Table 2. Chamfer dimension Limits**

Chamfer dimension Nominal r	r		Corner of shaft R
	Max	Min	Max
0.5	0.8	0.3	0.3
1	1.5	0.6	0.6
1.5	2	1	1
2	2.5	1.5	1
2.5	3	2	1.5
3	3.5	2.5	2
3.5	4	2.5	2
4	4.5	3	2.5
5	6	4	3

Table 3. Tolerance of cast iron housing

Unit:  $\mu\text{m}$ 

Spherical bearing seating diameter nominal $D_a$ (mm)		Tolerance symbol H7			Tolerance symbol J7			Tolerance symbol K7		
		Deviation of single plane mean dia. of bearing seating $\Delta D_{\text{am}}$		Bearing seating dia. variation in a single radial plane $VD_{\text{ap}}$	Deviation of single plane mean dia. of bearing seating $\Delta D_{\text{am}}$		Bearing seating dia. variation in a single radial plane $VD_{\text{ap}}$	Deviation of single plane mean dia. of bearing seating $\Delta D_{\text{am}}$		Bearing seating dia. variation in a single radial plane $VD_{\text{ap}}$
		High	Low	Max	High	Low	Max	High	Low	Max
Over	Incl.									
30	50	+25	0	10	+14	-11	10	+ 7	-18	10
50	80	+30	0	12	+18	-12	12	+ 9	-21	12
80	120	+35	0	14	+22	-13	14	+10	-25	14
120	180	+40	0	16	+26	-14	16	+12	-28	16
180	250	+46	0	18	+30	-16	18	+13	-33	18
250	315	+52	0	20	+36	-16	20	+16	-36	20

Notes: (1) Spherical bearing seat dimensions are divided into H7 for clearance fits and J7 and K7 for light interference fits. As NACHI bearings equipped with an anti-rotation pin to prevent outer race rotation, H7 is HACHI standard for the dimension.

(2) For rotating outer ring load or fluctuating load applications, J7 or K7 fitting practice should be used.

(3) Silver series of special alloy material are supplied with special tolerance.

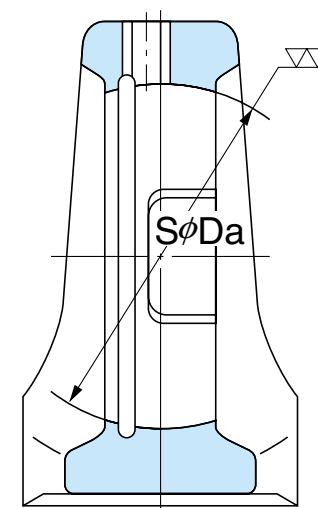





### 3. Radial clearance of Ball Bearings

Cylindrical bore	See <a href="#">Table 6.1</a> (Technical Information) ; Radial internal clearance of deep-groove ball bearings (with Cylindrical bore)
Tapered bore	CT2 : CN for cylindrical bore CTN : C3 for cylindrical bore CT3 : C4 for cylindrical bore They are considered the inner ring expansion by fitting with an adapter sleeve.

### 4. Shaft Tolerance

For cylindrical bore bearings	<ul style="list-style-type: none"> <li>● Normal load: Shaft tolerance h7, h8 or js7</li> <li>● Heavy or shock load: Shaft tolerance k6, k7 or m6</li> </ul>
For tapered bore bearings with an adaptor sleeve	<ul style="list-style-type: none"> <li>● Shaft tolerance h9</li> </ul>

### 5. Maximum permissible misalignment angle

Normal permissible misalignment angle  $\alpha$  is  $\pm 1.5^\circ \sim 2.5^\circ$  because it is restricted to grease supply.

Even if grease is not supplied, it is desirable to use at same limiting value.

If larger angles are needed, its angle is permissible to about  $\pm 5^\circ$ .

The maximum misalignment angle of bearing units with a housing cover is  $\pm 1.0^\circ \sim 1.8^\circ$ , beyond this angle the inner diameter of the cover will interfere the shaft.

To prevent the unequal contact between seals and shaft, the heat generation and the dust intrusion, misalignment angle should be minimized.

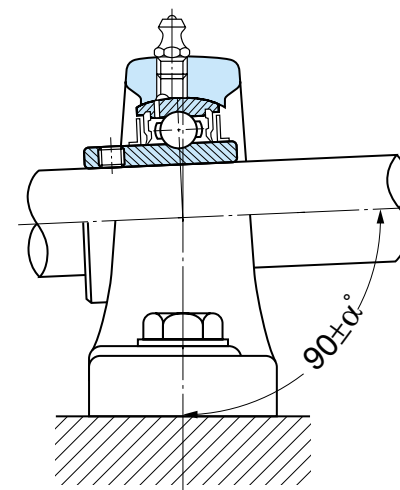



## 6. Maximum permissible operating temperature

Since Bearing units are sometimes used at higher or lower temperature than normal, NACHI prepares the special specification shown in Table 4.

In case of Bearing units with high temperature specification, the decrease in basic load rating should be considered. And radial clearance should be larger than normal clearance.

NACHI standard radial clearance for high temperature applications is C3 HR4, C4 HR5 and C4 HR23 for cylindrical bore bearings and CT3 HR4, CT4 HR23 for tapered bore bearings.

If there is large temperature difference between inner ring and outer ring, radial internal clearance should be determined reasonably.

- Notes
1. If operating temperature exceeds 150°C, careful investigation including radial internal clearance is required.  
In such case, Please consult NACHI with operating conditions.
  2. The grease shown in Table 4 must be supplied for relubrication. If the different grease are mixed, lubrication ability can deteriorate. Before supplying different grease, please consult NACHI or grease manufacture.

**Table 4. Operating Temperature Range**

Series	Seal material	Grease	Operating temperature range (°C)	Slinger color
Silver series	Nitrile rubber (NBR)	Alvania Grease 2	- 10 ~ + 80	-
Standard	Nitrile rubber (NBR)	Alvania Grease 3	- 15 ~ +100	Black
HR4 for high temperature	Nitrile rubber (NBR)	Superlube 3	Normal temperature ~ +120	Yellow
HR5 for high temperature	Silicone rubber	Superlube 3	Normal temperature ~ +200	Yellow
HR23 for high temperature	Silicone rubber	Fluorine-contained Grease	Normal temperature ~ +230	Black
CR2A for low temperature	Silicone rubber	Aero Shell Grease 7	- 40 ~ +Normal temperature	White





## 7. Speed limit

Limiting speed of bearings is determined by the slip speed limit between the seal and inner ring or shaft.

Limiting speed of bearings is shown in the chart below. But this limiting speed should be decreased, if there are difference between shaft center and bearing center or a mixing resistance of grease for HR23 specification. When Bearing units are operated in excess of speed limit, please consult NACHI.

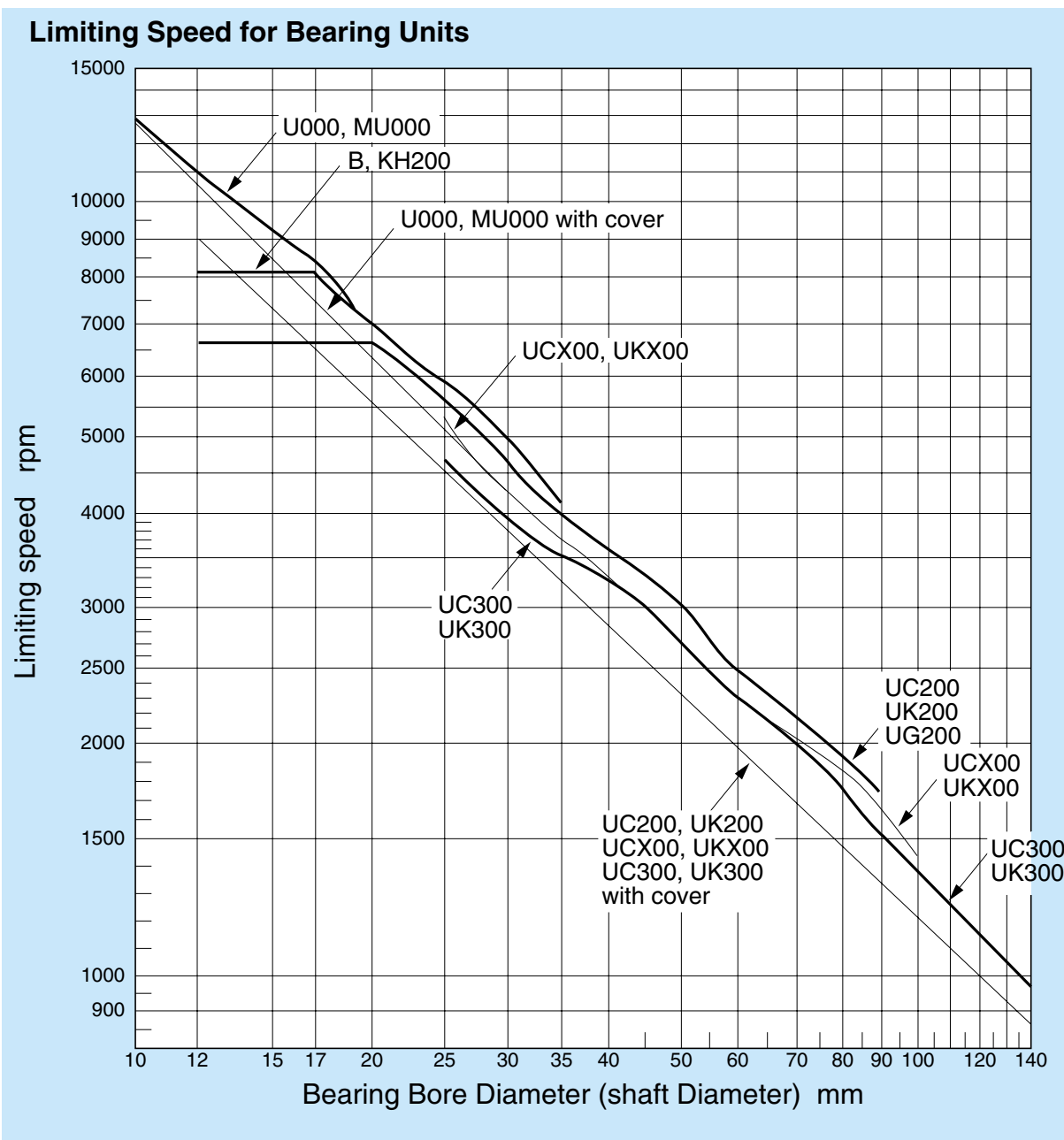

# Plummer Block Housings

Plummer Block housings ease to constitute bearing units by using with self-aligning ball bearings or spherical roller bearings. NACHI Plummer Block housing design is improved in term of accuracy, strength and rigidity.

## Features

- Wide range of sizes and configurations allows selection of optimal housing.
- Low weight to strength ratio.
- For straight shaft, the bearings with tapered bore and adapter can be mounted at any selected shaft position.
- For stepped-shaft, the bearings with cylindrical bore are fixed by shaft nut.

## Table of contents

Type		Symbol	Bore diameter on both sides	Applicable Bearing	Shaft Dia. (mm)
Split type	SN Standard type	SN5	Same	Tapered bore with adapter	20 ~ 140
		SN6			20 ~ 140
		SN30			10 ~ 170
		SN31			00 ~ 170
	SN Flat bottom type	SN5F	Same	Tapered bore with adapter	20 ~ 140
		SN6F			20 ~ 140
	SN Large bore dia on both sides	SN2	Same	Cylindrical bore	25 ~ 160
		SN3			25 ~ 85
		SN2C	Difference	Cylindrical bore	25 ~ 160
		SN3C			25 ~ 85
	SN Large bore dia on both sides Flat bottom	SN2F	Same	Cylindrical bore	25 ~ 160
		SN3F			25 ~ 85
		SN2FC	Difference	Cylindrical bore	25 ~ 160
		SN3FC			25 ~ 85
	SD Standard type	SD5	Same	Tapered bore with adapter	150 ~ 300
		SD6			150 ~ 260
SD30		150 ~ 300			
SD31		150 ~ 300			
One-piece type	V Standard type	V	Same	Tapered bore with adapter	30 ~ 200
			Difference	Cylindrical bore	35 ~ 220

Remark: Please contact NACHI for housings not listed in table, special dimension, and with special accessories.



## 1. Materials for Plummer Block Housings

NACHI Plummer Block housings are made of gray cast iron FC200. Spheroidal graphite iron castings FCD450 or carbon steel castings SC450 can be used for severe conditions such as vibration, shock and heavy load.

Materials for accessories are shown in right table.

### Materials for Accessories

Accessory	Material	Symbol
Bolt	Rolled steels for general structure	SS400
Spring lock washer	High carbon steel wire rods	SWRH62B
Cover of V series	Gray iron castings	FC200
Oil seal	Nitrile rubber	NBR
Drainage plug	Carbon steels for machine structure use	S10C
Eyebolt	Rolled steels for general structure	SS400
Grease nipple	Free-cutting brass	C3604B
Locating ring	Gray iron castings	FC200
Adapter sleeve, Locknut, Lockplate	Carbon steels for machine structure use or Rolled steels for general structure	S25C or SS400
Plain washer	Rolled steels for general structure	SS400





## 2. Designations

### (1) Plummer Block Housings

Designations of Plummer Block Housings are shown as follows.

#### • One-piece housings

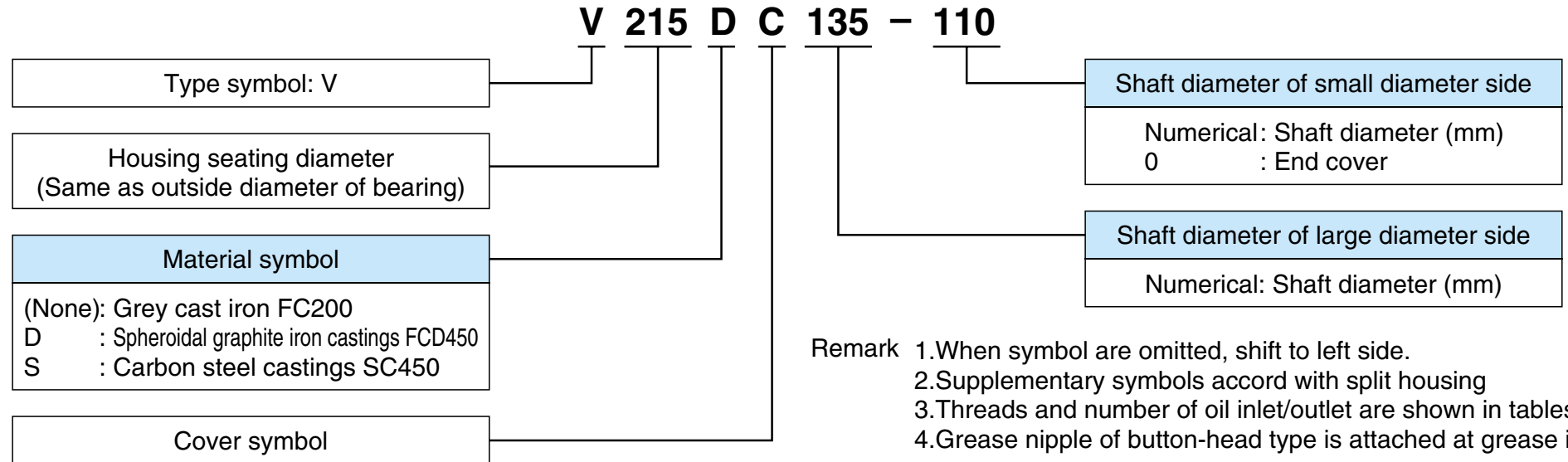



• Split-housings

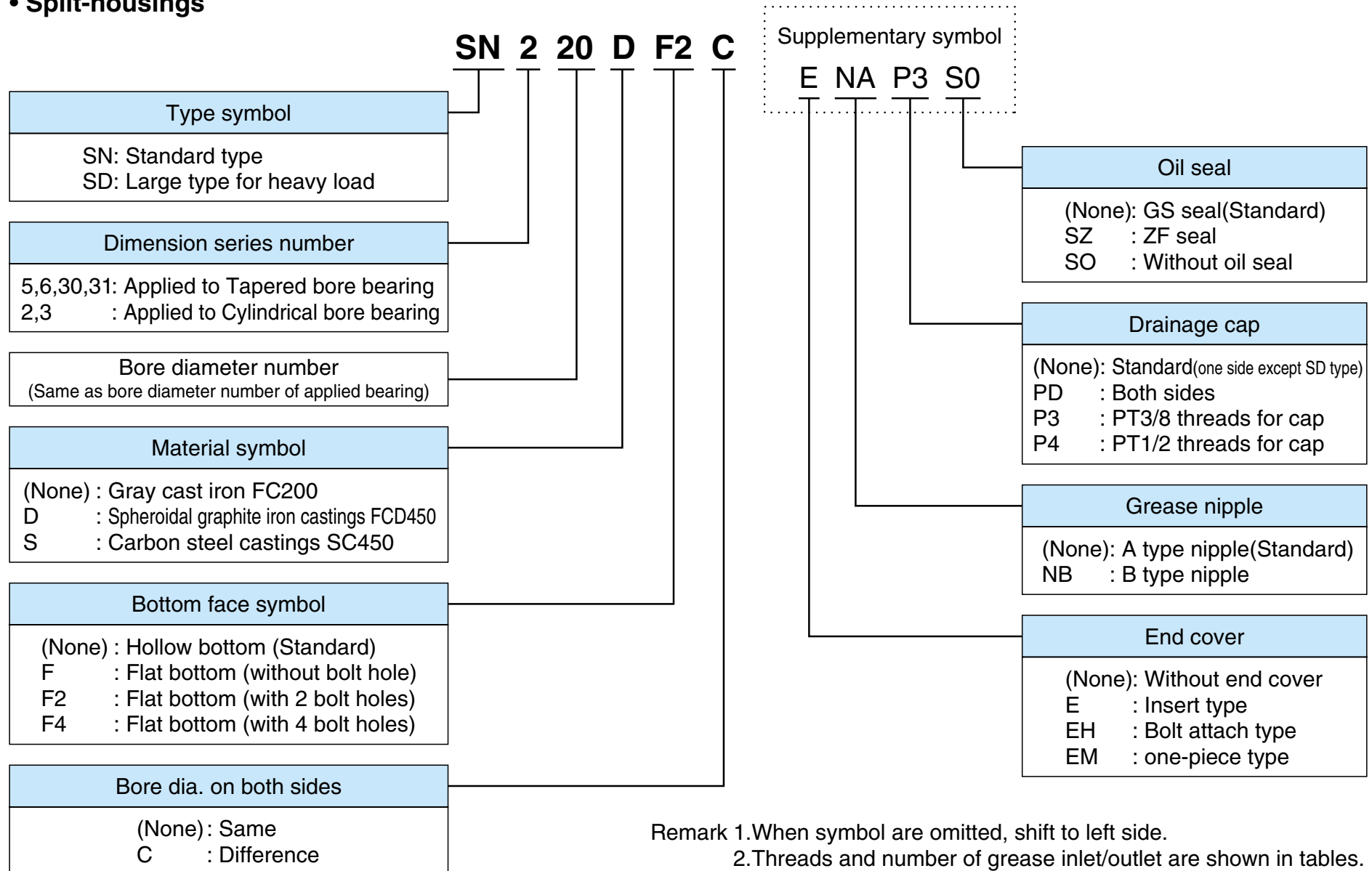

- Remark 1. When symbol are omitted, shift to left side.  
 2. Threads and number of grease inlet/outlet are shown in tables.  
 3. Grease nipple A type is attached at grease inlet.





## (2) Locating Rings

Locating ring for fixed side housing is identified as follows.

locating ring should be prepared besides plummer block housings.

The dimension table show the designation and number of ring required for each bearing.

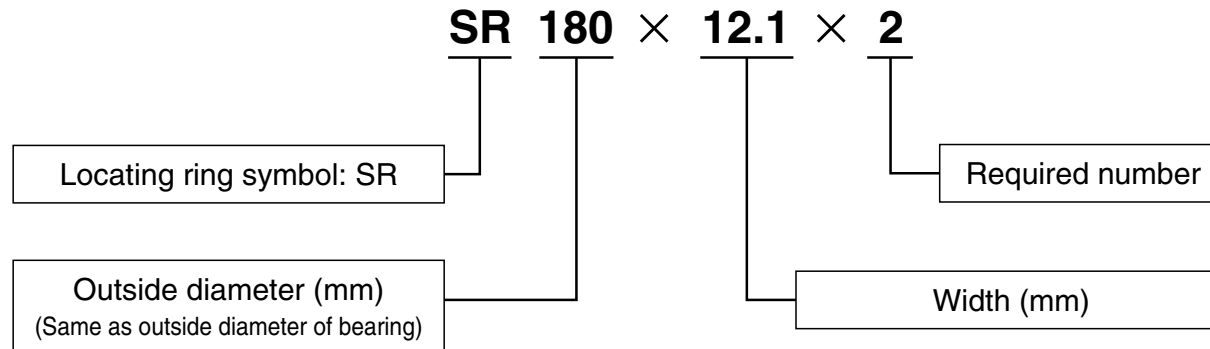

## (3) Combination of Plummer Block Housing, Bearing, Adapter and Locating Ring

The designations of combination are obtained by adding each with '+' as following order.

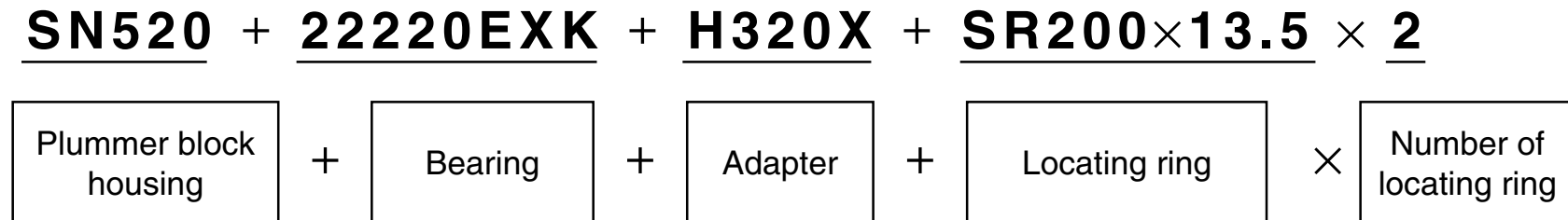

Remark: Designations for parts not required are omitted.







### 3. Tolerances for Plummer Block Housings

The tolerances of housing seating bore, width and height from mounting face to centerline of housing seating bore are shown in dimension tables.

The bore diameter and tolerance of the openings at both sides of housings are shown in right table.

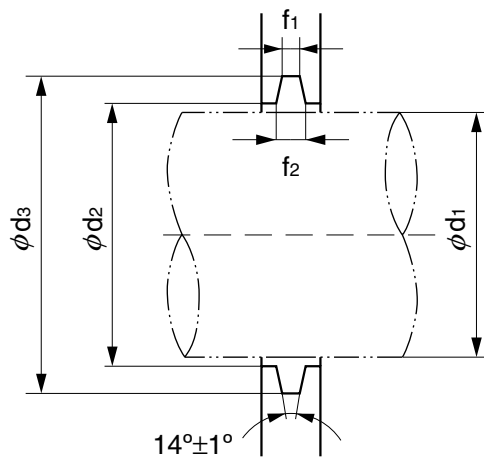

Side opening of housing

#### Dimensions and Tolerances of Side Openings

(1/3)

Unit: mm

Shaft Dia		d <sub>2</sub>		d <sub>3</sub>		f <sub>1</sub>		f <sub>2</sub>	Oil seal
d <sub>1</sub>	Nominal	Tolerance (H12)		Nominal	Tolerance (H12)	Nominal	Tolerance (H13)	Nominal	(Ref.)
20	21.5	+0.210 0		31	+0.250 0	3	+0.140 0	4.2	GS 5
25	26.5	+0.250 0		38		4		5.4	GS 6
30	31.5			43		4		5.4	GS 7
35	36.5	+0.250 0		48	+0.300 0	4	+0.180 0	5.4	GS 8
40	41.5	+0.300 0		53		4		5.4	GS 9
45	46.5			58		4		5.4	GS 10
50	51.5	+0.300 0		67	+0.350 0	5	+0.220 0	6.9	GS 11
55	56.5			72		5		6.9	GS 12
60	62			77		5		6.9	GS 13
65	67	+0.350 0		82	+0.400 0	5	+0.220 0	6.8	GS 15
70	72			89		6		8.1	GS 16
75	77			94		6		8.1	GS 17
80	82	+0.350 0		99	+0.400 0	6	+0.220 0	8.1	GS 18
85	87			104		6		8.1	GS 19
90	92			111		7		9.3	GS 20
95	97	+0.350 0		116	+0.400 0	7	+0.220 0	9.3	GS 21
100	102			125		8		10.8	GS 22
105	107			130		8		10.8	GS 23

Remark: Number of oil seal is applicable to ZF seal with same number.





## Dimensions and Tolerances of Side Openings

(2/3)

Unit: mm

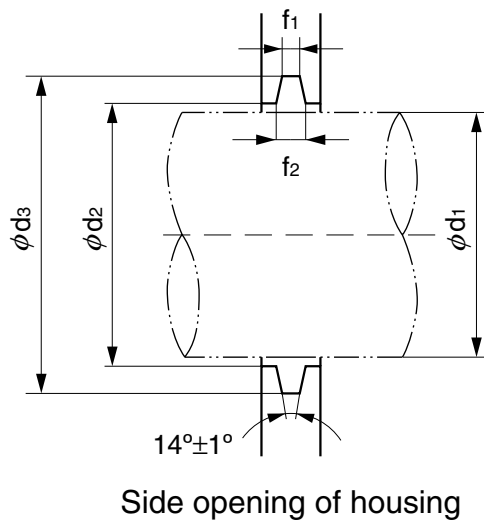

Shaft Dia		d <sub>2</sub>		d <sub>3</sub>		f <sub>1</sub>		f <sub>2</sub>	Oil seal (Ref.)
d <sub>1</sub>	Nominal	Tolerance (H12)		Nominal	Tolerance (H12)	Nominal	Tolerance (H13)	Nominal	
<b>110</b>	113			135		8	+0.220 0	10.7	GS 24
<b>115</b>	118			140		8		10.7	GS 26
<b>120</b>	123			145		8		10.7	GS 27
<b>125</b>	128	+0.400 0		154	+0.400 0	9		12.2	GS 28
<b>130</b>	133			159		9		12.2	GS 29
<b>135</b>	138			164		9		12.2	GS 30
<b>140</b>	143			173	+0.400 0	10		13.7	GS 32
<b>145</b>	148			178		10		13.7	GS 33
<b>150</b>	153			183		10		13.7	GS 34
<b>155</b>	158	+0.400 0		188		10	+0.220 0	13.7	GS 35
<b>160</b>	163			193		10		13.7	GS 36
<b>165</b>	168			198		10		13.7	GS 37
<b>170</b>	173			203	+0.460 0	10		13.7	GS 38
<b>175</b>	178			208		10		13.7	GS 39
<b>180</b>	183			213		10		13.7	GS 40
<b>190</b>	193	+0.460 0		223		10	+0.270 0	13.7	GS 42
<b>200</b>	203			240		11		15.5	GS 44
<b>210</b>	213			250		11		15.5	GS 46

Remark: Number of oil seal is applicable to ZF seal with same number.





## Dimensions and Tolerances of Side Openings

(3/3)

Unit: mm

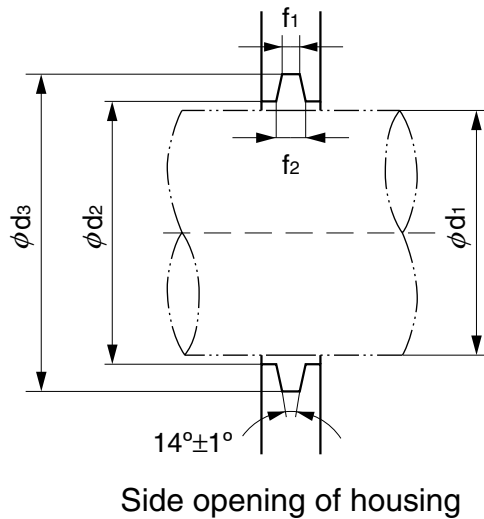

Shaft Dia		d <sub>2</sub>		d <sub>3</sub>		f <sub>1</sub>		f <sub>2</sub>	Oil seal (Ref.)
d <sub>1</sub>	Nominal	Tolerance (H12)		Nominal	Tolerance (H12)	Nominal	Tolerance (H13)	Nominal	
<b>220</b>	223			260	+0.520 0	11		15.5	GS 48
<b>230</b>	233			270		11		15.5	GS 50
<b>240</b>	243			286		12		17.3	GS 52
<b>250</b>	253	+0.520 0		296		12		17.3	GS 54
<b>260</b>	263			12		17.3		GS 56	
<b>270</b>	273			13		19		GS 58	
<b>280</b>	283	+0.570 0		332	+0.570 0	13	+0.270 0	19	GS 60
<b>300</b>	303			13		19		GS 64	
<b>320</b>	323			14		19.8		GS 68	
<b>340</b>	343	+0.570 0		390		14		19.8	GS 72
<b>360</b>	363			13		19		GS 76	
<b>380</b>	383			13		19		GS 80	
<b>400</b>	403	+0.630 0		452	+0.630 0	14		20	GS 84
<b>410</b>	413			14		19.8		GS 88	
<b>430</b>	433			14		19.8		GS 92	
<b>450</b>	453			505	+0.700 0	14		20.3	GS 96

Remark: Number of oil seal is applicable to ZF seal with same number.





## Applicable Bearings

Bearing type Housing type	Self-aligning Ball Bearing				Spherical Roller Bearing					
	12	22	13	23	230	231	222	232	213	223
SN5 SN5F	05K ~ 22K	05K ~ 22K	—	—	—	—	05K ~ 32K	18K ~ 32K	—	—
SN6 SN6F	—	—	05K ~ 22K	05K ~ 22K	—	—	—	—	05K ~ 22K	08K ~ 32K
SN30	—	—	—	—	24K ~ 38K	—	—	—	—	—
SN31	—	—	—	—	—	22K ~ 38K	—	—	—	—
SN2 SN2F	05 ~ 22	05 ~ 22	—	—	—	—	05 ~ 32	18 ~ 32	—	—
SN3 SN3F	—	—	05 ~ 17	05 ~ 17	—	—	—	—	05 ~ 17	08 ~ 17
SD5	—	—	—	—	—	—	34K ~ 64K	—	—	—
SD6	—	—	—	—	—	—	—	—	—	34K ~ 56K
SD30	—	—	—	—	34K ~ 64K	—	—	—	—	—
SD31	—	—	—	—	—	34K ~ 64K	—	—	—	—
V	08(K) ~ 22(K)	08(K) ~ 22(K)	07(K) ~ 22(K)	07(K) ~ 22(K)	22(K) ~ 44(K)	22(K) ~ 40(K)	08(K) ~ 38(K)	22(K) ~ 38(K)	07(K) ~ 22(K)	08(K) ~ 32(K)

**Table 5.1.2 Tolerance Values of Outer Ring**

(1/4)

Unit:  $\mu\text{m}$

Bearing outside diameter Nominal D (mm)		Bearing outside diameter													
		Single plane mean outside diameter deviation $\Delta D_{mp}$										Deviation of a single outside diameter $\Delta D_s$			
		Class 0		Class 6		Class 5		Class 4		Class 2		Class 4		Class 2	
		Diameter series 0,1,2,3,4													
Over	Incl.	High	Low	High	Low	High	Low	High	Low	High	Low	High	Low	High	Low
2.5 <sup>(1)</sup>	6	0	-8	0	-7	0	-5	0	-4	0	-2.5	0	-4	0	-2.5
6	18	0	-8	0	-7	0	-5	0	-4	0	-2.5	0	-4	0	-2.5
18	30	0	-9	0	-8	0	-6	0	-5	0	-4	0	-5	0	-4
30	50	0	-11	0	-9	0	-7	0	-6	0	-4	0	-6	0	-4
50	80	0	-13	0	-11	0	-9	0	-7	0	-4	0	-7	0	-4
80	120	0	-15	0	-13	0	-10	0	-8	0	-5	0	-8	0	-5
120	150	0	-18	0	-15	0	-11	0	-9	0	-5	0	-9	0	-5
150	180	0	-25	0	-18	0	-13	0	-10	0	-7	0	-10	0	-7
180	250	0	-30	0	-20	0	-15	0	-11	0	-8	0	-11	0	-8
250	315	0	-35	0	-25	0	-18	0	-13	0	-8	0	-13	0	-8
315	400	0	-40	0	-28	0	-20	0	-15	0	-10	0	-15	0	-10
400	500	0	-45	0	-33	0	-23	-	-	-	-	-	-	-	-
500	630	0	-50	0	-38	0	-28	-	-	-	-	-	-	-	-
630	800	0	-75	0	-45	0	-35	-	-	-	-	-	-	-	-
800	1000	0	-100	0	-60	-	-	-	-	-	-	-	-	-	-
1000	1250	0	-125	-	-	-	-	-	-	-	-	-	-	-	-
1250	1600	0	-160	-	-	-	-	-	-	-	-	-	-	-	-
1600	2000	0	-200	-	-	-	-	-	-	-	-	-	-	-	-
2000	2500	0	-250	-	-	-	-	-	-	-	-	-	-	-	-

- Notes: (1) This diameter is included in this group.  
 (2) Applies before mounting and after removal of internal or external snap ring.  
 (3) Applies to radial ball bearings such as deep groove ball bearings, angular contact ball bearings.  
 (4) Outer ring width variation of class 0 and 6 are listed in Table 5.1.1.  
 (5) Applies to radial ball bearings such as deep groove ball bearing, angular contact ball bearings.

Remarks: The high deviation of bearing cylindrical bore diameter specified in this table does not apply within a distance of  $1.2 \times r$  (max) from the ring face.



**Table 5.1.2 Tolerance Values of Outer Ring**

(2/4)

Unit:  $\mu\text{m}$

Bearing outside diameter Nominal D (mm)		Bearing outside diameter												
		Outside diameter variation in a single radial plane (2)												
		$V_{Dp}$												
		Class 0				Class 6				Class 5		Class 4		Class 2
		Open bearing		Seal · shield bearing		Open bearing		Seal · shield bearing		Open bearing		Open bearing		Open bearing
Diameter series		Diameter series		Diameter series		Diameter series		Diameter series		Diameter series		Diameter series		Open bearing
7,8,9	0,1	2,3,4	2,3,4	7,8,9	0,1	2,3,4	0,1,2,3,4	7,8,9	0,1,2,3,4	7,8,9	0,1,2,3,4	7,8,9	0,1,2,3,4	Open bearing
Over	Incl.	Max	Max	Max	Max	Max	Max	Max	Max	Max	Max	Max	Max	Max
2.5 <sup>(1)</sup>	6	10	8	6	10	9	7	5	9	5	4	4	3	2.5
6	18	10	8	6	10	9	7	5	9	5	4	4	3	2.5
18	30	12	9	7	12	10	8	6	10	6	5	5	4	4
30	50	14	11	8	16	11	9	7	13	7	5	6	5	4
50	80	16	13	10	20	14	11	8	16	9	7	7	5	4
80	120	19	19	11	26	16	16	10	20	10	8	8	6	5
120	150	23	23	14	30	19	19	11	25	11	8	9	7	5
150	180	31	31	19	38	23	23	14	30	13	10	10	8	7
180	250	38	38	23	—	25	25	15	—	15	11	11	8	8
250	315	44	44	26	—	31	31	19	—	18	14	13	10	8
315	400	50	50	30	—	35	35	21	—	20	15	15	11	10
400	500	56	56	34	—	41	41	25	—	23	17	—	—	—
500	630	63	63	38	—	48	48	29	—	28	21	—	—	—
630	800	94	94	55	—	56	56	34	—	35	26	—	—	—
800	1000	125	125	75	—	75	75	45	—	—	—	—	—	—
1000	1250	—	—	—	—	—	—	—	—	—	—	—	—	—
1250	1600	—	—	—	—	—	—	—	—	—	—	—	—	—
1600	2000	—	—	—	—	—	—	—	—	—	—	—	—	—
2000	2500	—	—	—	—	—	—	—	—	—	—	—	—	—

- Notes: (1) This diameter is included in this group.  
 (2) Applies before mounting and after removal of internal or external snap ring.  
 (3) Applies to radial ball bearings such as deep groove ball bearings, angular contact ball bearings.  
 (4) Outer ring width variation of class 0 and 6 are listed in Table 5.1.1.  
 (5) Applies to radial ball bearings such as deep groove ball bearing, angular contact ball bearings.

Remarks: The high deviation of bearing cylindrical bore diameter specified in this table does not apply within a distance of  $1.2 \times r$  (max) from the ring face.

**Table 5.1.2 Tolerance Values of Outer Ring**

(3/4)

Unit:  $\mu\text{m}$

Bearing outside diameter Nominal D (mm)		Bearing outside diameter					Radial runout of assembled bearing outer ring					Variation of bearing outside surface generatrix inclination with outer ring reference face		
		Mean outside diameter variation (2)					Radial runout of assembled bearing outer ring					SD		
		$V_{Dmp}$					$K_{ea}$					$S_D$		
Over	Incl.	Class 0	Class 6	Class 5	Class 4	Class 2	Class 0	Class 6	Class 5	Class 4	Class 2	Class 5	Class 4	Class 2
		Max	Max	Max	Max	Max	Max	Max	Max	Max	Max	Max	Max	Max
2.5 <sup>(1)</sup>	6	6	5	3	2	1.5	15	8	5	3	1.5	8	4	1.5
6	18	6	5	3	2	1.5	15	8	5	3	1.5	8	4	1.5
18	30	7	6	3	2.5	2	15	9	6	4	2.5	8	4	1.5
30	50	8	7	4	3	2	20	10	7	5	2.5	8	4	1.5
50	80	10	8	5	3.5	2	25	13	8	5	4	8	4	1.5
80	120	11	10	5	4	2.5	35	18	10	6	5	9	5	2.5
120	150	14	11	6	5	2.5	40	20	11	7	5	10	5	2.5
150	180	19	14	7	5	3.5	45	23	13	8	5	10	5	2.5
180	250	23	15	8	6	4	50	25	15	10	7	11	7	4
250	315	26	19	9	7	4	60	30	18	11	7	13	8	5
315	400	30	21	10	8	5	70	35	20	13	8	13	10	7
400	500	34	25	12	—	—	80	40	23	—	—	15	—	—
500	630	38	29	14	—	—	100	50	25	—	—	18	—	—
630	800	55	34	18	—	—	120	60	30	—	—	20	—	—
800	1000	75	45	—	—	—	140	75	—	—	—	—	—	—
1000	1250	—	—	—	—	—	160	—	—	—	—	—	—	—
1250	1600	—	—	—	—	—	190	—	—	—	—	—	—	—
1600	2000	—	—	—	—	—	220	—	—	—	—	—	—	—
2000	2500	—	—	—	—	—	250	—	—	—	—	—	—	—

Notes: (1) This diameter is included in this group.

(2) Applies before mounting and after removal of internal or external snap ring.

(3) Applies to radial ball bearings such as deep groove ball bearings, angular contact ball bearings.

(4) Outer ring width variation of class 0 and 6 are listed in Table 5.1.1.

(5) Applies to radial ball bearings such as deep groove ball bearing, angular contact ball bearings.

Remarks: The high deviation of bearing cylindrical bore diameter specified in this table does not apply within a distance of  $1.2 \times r$  (max) from the ring face.

**Table 5.1.2 Tolerance Values of Outer Ring****(4/4)**

Bearing outside diameter Nominal D (mm)		Assembled bearing outer ring face runout with raceway $S_{ea}$ (3)			Outer ring width variation $V_{Cs}$ (4)		
		Class 5	Class 4	Class 2	Class 5	Class 4	Class 2
Over	Incl.	Max	Max	Max	Max	Max	Max
2.5 <sup>(1)</sup>	6	8	5	1.5	5	2.5	1.5
6	18	8	5	1.5	5	2.5	1.5
18	30	8	5	2.5	5	2.5	1.5
30	50	8	5	2.5	5	2.5	1.5
50	80	10	5	4	6	3	1.5
80	120	11	6	5	8	4	2.5
120	150	13	7	5	8	5	2.5
150	180	14	8	5	8	5	2.5
180	250	15	10	7	10	7	4
250	315	18	10	7	11	7	5
315	400	20	13	8	13	8	7
400	500	23	—	—	15	—	—
500	630	25	—	—	18	—	—
630	800	30	—	—	20	—	—
800	1000	—	—	—	—	—	—
1000	1250	—	—	—	—	—	—
1250	1600	—	—	—	—	—	—
1600	2000	—	—	—	—	—	—
2000	2500	—	—	—	—	—	—

Notes: (1) This diameter is included in this group.

(2) Applies before mounting and after removal of internal or external snap ring.

(3) Applies to radial ball bearings such as deep groove ball bearings, angular contact ball bearings.

(4) Outer ring width variation of class 0 and 6 are listed in Table 5.1.1.

(5) Applies to radial ball bearings such as deep groove ball bearing, angular contact ball bearings.

Remarks: The high deviation of bearing cylindrical bore diameter specified in this table does not apply within a distance of  $1.2 \times r$  (max) from the ring face.



**Table 5.7.1 1/12 Tapered Bore (Class 0)**

Unit:  $\mu\text{m}$

Nominal bearing bore dimension d (mm)		Mean bore diameter deviation at theoretical small end of a tapered bore				Bore diameter variation in a single radial plane (1)(2)
		$\Delta d_{mp}$		$\Delta d_{1mp} - \Delta d_{mp}$		$Vdp$
Over	Incl.	High	Low	High	Low	Max
	10	+ 22	0	+ 15	0	9
10	18	+ 27	0	+ 18	0	11
18	30	+ 33	0	+ 21	0	13
	30	+ 39	0	+ 25	0	16
30	50	+ 46	0	+ 30	0	19
50	80	+ 54	0	+ 35	0	22
	120	+ 63	0	+ 40	0	40
120	180	+ 72	0	+ 46	0	46
180	250	+ 81	0	+ 52	0	52
	315	+ 89	0	+ 57	0	57
315	400	+ 97	0	+ 63	0	63
400	500	+110	0	+ 70	0	70
	630	+125	0	+ 80	0	—
630	800	+140	0	+ 90	0	—
800	1000	+165	0	+105	0	—
1000	1250	+195	0	+125	0	—
1250	1600					

Note: (1) Applicable to all radial planes of tapered bore.

(2) Not applicable to bearings of diameter series 7 and 8.

**Table 6.1 Radial Internal Clearance of Deep-groove Ball Bearings (with Cylindrical Bore) (JIS) (1/2)** Unit:  $\mu\text{m}$

Bearing bore dia. Nominal d (mm)		Radial clearance									
		C2		CN (Normal)		C3		C4		C5	
Over	Incl.	min	max	min	max	min	max	min	max	min	max
2.5	6	0	7	2	13	8	23	—	—	—	—
6	10	0	7	2	13	8	23	14	29	20	37
10	18	0	9	3	18	11	25	18	33	25	45
18	24	0	10	5	20	13	28	20	36	28	48
24	30	1	11	5	20	13	28	23	41	30	53
30	40	1	11	6	20	15	33	28	46	40	64
40	50	1	11	6	23	18	36	30	51	45	73
50	65	1	15	8	28	23	43	38	61	55	90
65	80	1	15	10	30	25	51	46	71	65	105
80	100	1	18	12	36	30	58	53	84	75	120
100	120	2	20	15	41	36	66	61	97	90	140
120	140	2	23	18	48	41	81	71	114	105	160
140	160	2	23	18	53	46	91	81	130	120	180
160	180	2	25	20	61	53	102	91	147	135	200
180	200	2	30	25	71	63	117	107	163	150	230





**Table 6.1 Radial Internal Clearance of Deep-groove Ball Bearings (with Cylindrical Bore) (JIS) (2/2)** Unit:  $\mu\text{m}$

Bearing bore dia. Nominal d (mm)		Radial clearance									
		C2		CN (Normal)		C3		C4		C5	
Over	Incl.	min	max	min	max	min	max	min	max	min	max
200	225	2	35	25	85	75	140	125	195	175	265
225	250	2	40	30	95	85	160	145	225	205	300
250	280	2	45	35	105	90	170	155	245	225	340
280	315	2	55	40	115	100	190	175	270	245	370
315	355	3	60	45	125	110	210	195	300	275	410
355	400	3	70	55	145	130	240	225	340	315	460
400	450	3	80	60	170	150	270	250	380	350	510
450	500	3	90	70	190	170	300	280	420	390	570
500	560	10	100	80	210	190	330	310	470	440	630
560	630	10	110	90	230	210	360	340	520	490	690
630	710	20	130	110	260	240	400	380	570	540	760
710	800	20	140	120	290	270	450	430	630	600	840
800	900	20	160	140	320	300	500	480	700	670	940
900	1000	20	170	150	350	330	550	530	770	740	1040
1000	1120	20	180	160	380	360	600	580	850	820	1150
1120	1250	20	190	170	410	390	650	630	920	890	1260