

This document is the property of REGAL BELOIT CORPORATION ("RBC") including its subsidiaries and divisions and contains proprietary information of RBC. This document is loaned on the express condition that neither it nor the information contained therein shall be disclosed to others without the express written consent of RBC, and that the information shall be used by the recipient only as approved expressly by RBC. This document shall be returned to RBC upon its request. This document may be subject to certain restrictions under U.S. export control laws and regulations.

NOTES:

- 1) MANUAL OVERLOAD PROTECTOR.
- 2) FLINGER ON SHAFT.
- 3) GASKETS THROUGHOUT.
- 4) DRAIN HOLE IN FRAME (BOTH ENDS).

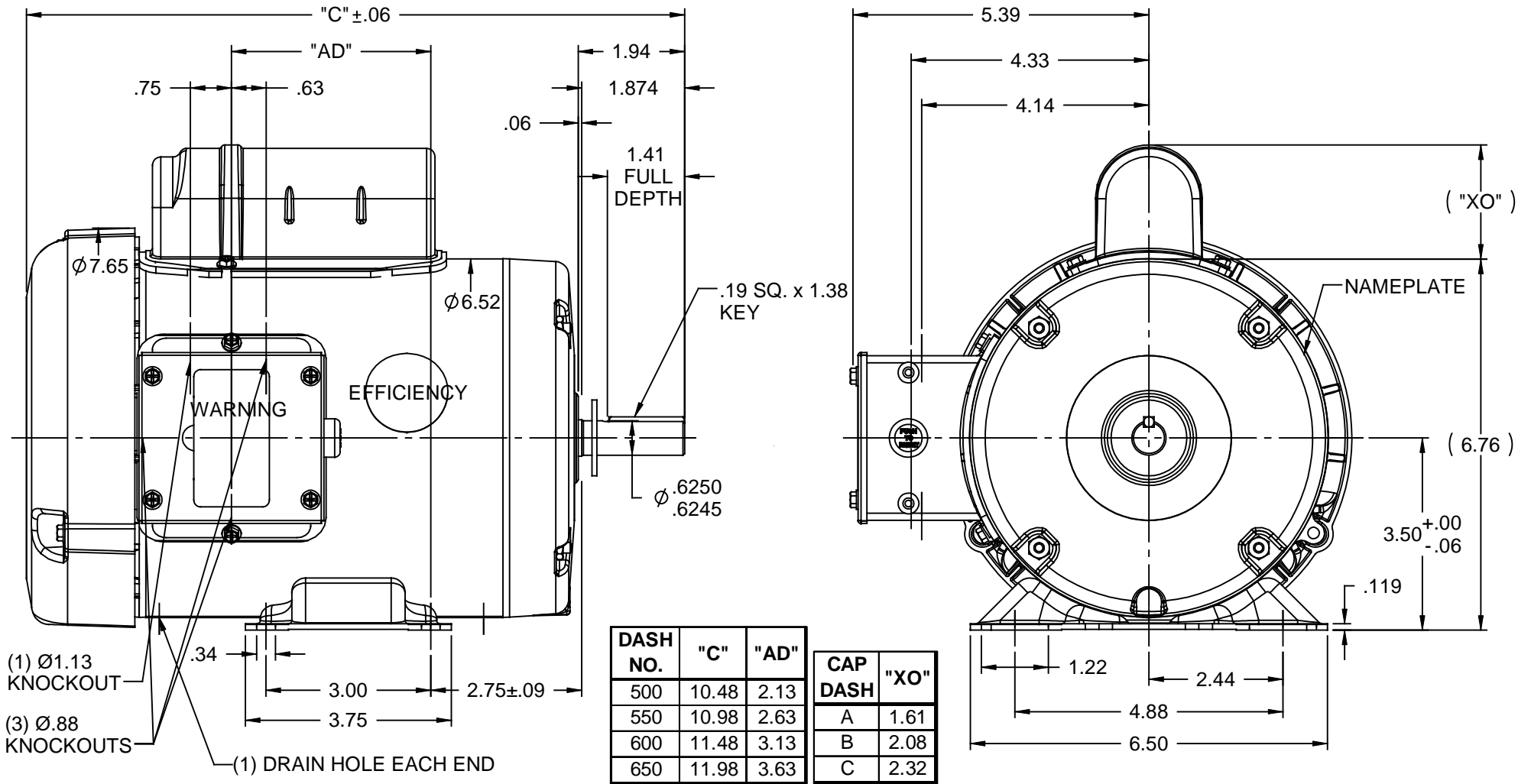

		TOLERANCES UNLESS SPECIFIED		ELECTRIC MOTORS GEARMOTORS AND DRIVES	DRAWN KMM 08/09/07
		DEC	INCHES		CHK
		.X	±.1		APPR
		.XX	±.03		SCALE 3:8
		.XXX	±.005		REF 032507
01	ADD DRAIN HOLE NOTE PER ISAAC 08-1915	LST 5/7/08	XX .XXXX ±.0005	MAT'L	FMF 110088.00
NO	REVISION	BY & DATE	CHK ANG ±1/2°	FINISH GENERAL PURPOSE	PAGE OF
THIRD ANGLE PROJECTION			RFP	PREV	SIZE DRAWING NO
			NETWORK FILE NAME		<b>A</b> <b>028774</b>
					REV <b>01</b>