

FEATURES/BENEFITS

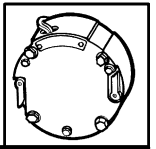

Motor Brakes

1. Rugged, die-cast aluminum housing mounts at any angle without modification.
2. Internally rectified DC voltage coil operates on either AC or DC voltage. Class B insulation is standard.
3. Splined hub permits uniform load distribution. Integral key design simplifies installation - no loose parts.
4. Single, non-asbestos friction disc design extends life, reduces replacement parts and allows quiet operation. (1)
5. Wave spring provides 360° of force when power is removed from the brake.
6. Wear adjustments are made external to brake - no disassembly required! Adjustments can be made in less than a minute by tightening each bolt to 50 in-lb of torque & then backing off 180° (1/2 turn).
7. Industry standard NEMA C-face mounting. Interchanges easily with competitive units.
8. Easy-to-use, reliable manual release levers reset automatically.

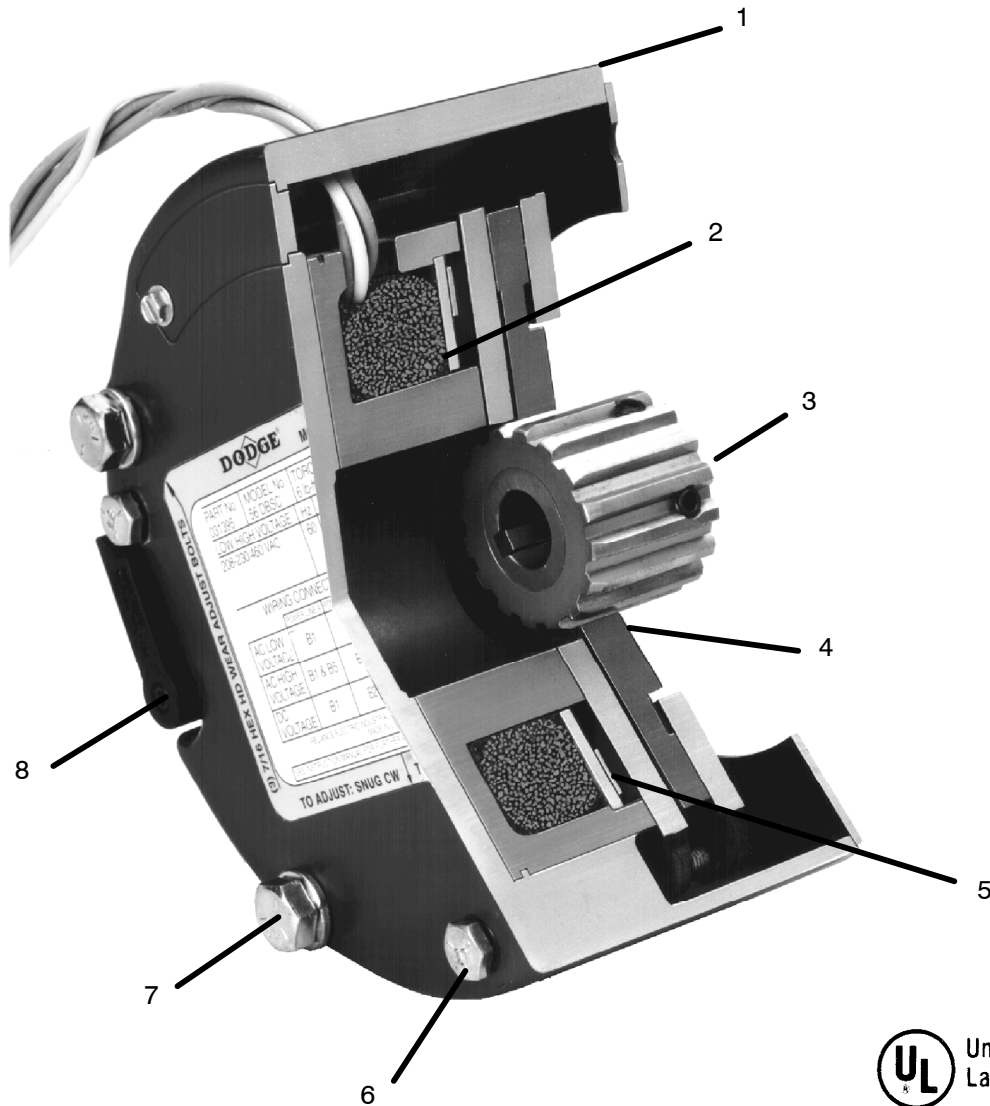

(1) 35 & 50 ft-lb motor brakes employ two friction discs and can be mounted at any angle without modification

